

RotorFlow Sensors Provide Visual Indication, Continuous Sensing and Accurate Switching

MEYLE generation of RotorFlow sensors, the RF-2500 Series, have been totally re-engineered with a one piece composite rotor, stronger uni-body construction, ceramic shafts and better sealing. The results are greater durability with broader chemical, temperature and pressure capabilities.

Today's RotorFlow Series are state of the art and offer you more options, better performance and durability than ever before...all at an affordable price geared for high volume, OEM applications. Select the RotorFlow sensor that is right for your application by choosing one of our three distinct configurations.

Select the RotorFlow sensor that is right for your application by choosing one of our three distinct configurations.

RFI - RotorFlow Indicator Types: For those who want simple visual confirmation of flow, RotorFlow RFI indicators provide the durable, low-cost answer. A bright, orange spinning rotor provides visual flow confirmation at a glance.

RFO - RotorFlow Output Types: For flow rate monitoring or metering applications. RotorFlow RFO Type sensors provide a pulsed or analog DC voltage output that is proportional to the rate of flow. The operating range of 4.5 to 24 VDC pulsed output is easily integrated into all digital logic families.

RFS - RotorFlow Switch Types: For specific flow setpoint switching, RotorFlow RFS type switches are one of the most reliable flow switches available. Setpoints are fully adjustable over the specified flow range. The dynamic operation of the rotor guards against jamming and false actuation.

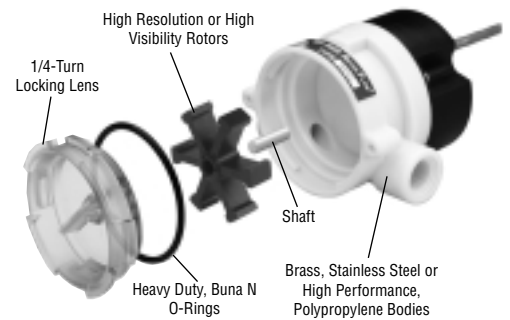

- ▶ Flow range from 0.4 to 225 l/min
- ▶ Bright, visual indication
- ▶ Choice of pulsed analogue DC output or adjustable 1 amp switched output
- ▶ Available in high performance plastic, brass or Stainless Steel housing

Installation and Maintenance

A proper installation will enhance RotorFlow sensor performance. Install using standard pipe fitting tools; horizontal fluid lines are recommended. For further installation and maintenance recommendations, refer to one of the following instruction bulletins: RFO Types - Part Number 157258; RFI Types - Part Number 157259; RFS Types - Part Number 157261. Since their function is to monitor dynamic fluid flow, naturally the rotor will react to turbulence, pulsation, entrained air, and other flow anomalies induced in the flow stream by other process hardware. For optimum performance, install RotorFlow units where nominal flow conditions exist with ports located at the top. Incoming flow may be placed on either port; a minimum of 20 cm of straight pipe on the inlet side is required. When operating in the low flow range, the supplied Low Flow Adapter must be installed in the incoming port.

Panel Mounting

Any RotorFlow sensors may be panel mounted using holes integrated into the bodies.

Two (2) mounting ears are provided at the body centre line to receive 3.5mm \varnothing self tapping screws (e.g. DIN 7971-B 3, 5 x 19) to accommodate panel mounting of the plastic RotorFlow units. See recommended panel preparation diagram (Fig. 2).

Note: ANSI T type 23 self-tapping screw are recommended. They may be replaced with standard machine screws if reinstallation should be required.

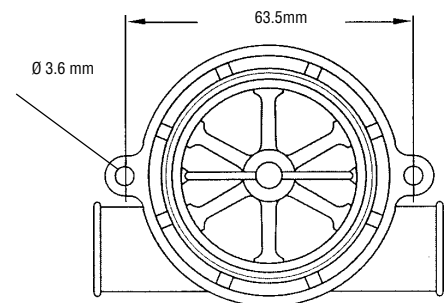
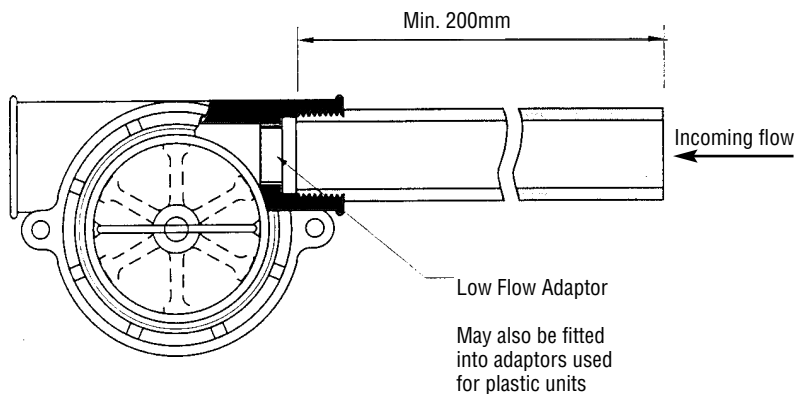

RotorFlow sensors connect to piping via NPT mating thread forms. The use of an appropriate thread sealant is necessary to assure a leak-tight connection. Permatex "No More Leaks" or 2 wraps of Teflon tape are the only sealants recommended for MEYLE flow sensors. 150 micron filtration is recommended. However, should foreign particles enter RotorFlow sensor, accumulation is easily cleared by removing the lens from the body. The lens is removed by turning its centre rib 45° counter-clockwise, and then pulling it out. To reinstall the lens, simply reverse the process.

Important: In either case, pressure must be relieved from the system prior to sensor clean-out.

Low Flow Applications

A low flow adaptor is supplied with all Rotorflow units. It is used to produce accurate response at low flow rates. Install the adaptor, as shown above, in the port selected for incoming flow.

RotorFlow - RFI-Types, Visual Indicators

This is RotorFlow in its most basic form – a bright orange rotor turning with fluid flow. Simple, direct and reliable.
Flow rate is estimated, or simply confirmed, by viewing the speed of the turning rotor. Either port may be used for incoming flow, and new bayonet mounting lens is easily removed for quick cleanout. RFI Type RotorFlow sensors are easy to see, easy to install and easy to afford.

Operating Principle

1. As liquid passes through the RotorFlow body the rotor spins at a rate proportional to flow.
2. RotorFlow Indicators may be mounted with flow entering either port. At low flow rates, performance is optimized by positioning ports at the top of the unit, in a horizontal plane.

Specifications

Wetted Materials	
Body	Polypropylene (Hydrolytically Stable, Glass Reinforced), SS or Brass
Rotor Pin	Ceramic
Rotor	Moulded Nylon, Colour: High Visibility Orange
Lens	Polysulfone
O-Ring	Buna N
Adaptor	Acetal
Max. Operating Pressure	Polypropylene Body: 7 bar Metal Body: 14 bar
Max. Operating Temperature	Polypropylene Body: 80 °C Metal Body: 100 °C
Typical Pressure Drop	See Graph (Page RFS)

Order Numbers

Body Material	Port Size	Flow Ranges (l/min)		Order Number	
		Low Range*	Standard Range	BSP	NPT
Polypropylene	1/4"	0.4 to 4.0	2.0 to 20.0	155420BSPP	155420
	1/2"	6.0 to 45.0	15.0 to 75.0	155480BSPP	155480
Brass	1/4"	0.4 to 4.0	2.0 to 20.0	142541BSPP	142541
	1/2"	6.0 to 45.0	15.0 to 75.0	142542BSPP	142542
	3/4"	---	7.5 to 112.5	180392BSPP	180392
	1"	---	15 to 225	181681BSPP	181681
Stainless Steel	9/16 x 18 UNF	0.4 to 4.0	2.0 to 20.0	N/A	174596
	1/2"	6 to 45	15.0 to 75.0	173138BSPP	173138
	3/4"	---	7.5 to 112.5	181682BSPP	181682
	1"	---	15 to 225	181683BSPP	181683

* With use of low flow adaptor supplied, see page 22

Notes:

1. Adaptors are supplied fitted to plastic units, sealed using Teflon (PTFE) tape.
2. If NPT thread is required for plastic units discard adaptor.
3. For pressure drop curves see RFS page.

Panel Meter for use with Rotorflow and FT-110



Typical Applications

- ▶ Visual flow confirmation on heat exchangers
- ▶ Plastic injection moulding equipment

Polypropylene Bodies

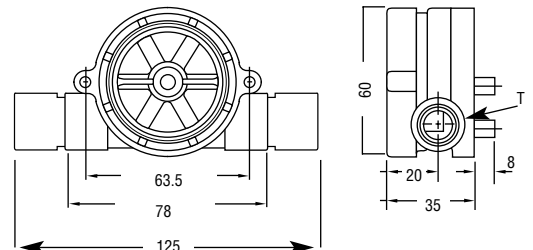

Adaptors, See Note 1

Metal Bodies

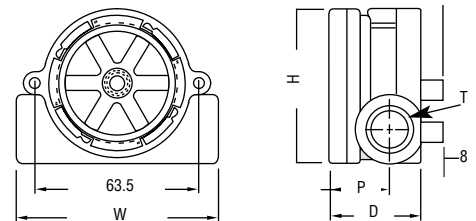

T	W	H	D	P
1/4	77	60	35	20
1/2	77	60	35	22
3/4	100	66	51	27
1	100	66	51	27

RotorFlow - RFO and RFA Types

4.5 - 24 VDC Pulsed Output

0 - 10 V, 4 to 20mA Linear Output

MEYLE sensors popularized the Rotor-Flow's paddlewheel design by combining high visibility rotors with solid-state electronics that are packaged into compact, panel mounting housings. They provide accurate flow rate output with integral visual confirmation ... all with an unprecedented price/performance ratio.

Typical Applications

Ensure proper processing, blending and dispensing operations on:

- ▶ Water Purification/Dispensing Systems
- ▶ Chemical Metering Equipment
- ▶ Water Sampling
- ▶ Ice Making Machinery
- ▶ Water Injection Systems
- ▶ Proof of Delivery Systems

Operating Principle:

- As liquid passes through the RotorFlow body the magnetic rotor spins at a rate proportional to flow. This causes a series of magnetic fields (the rotor vanes) to excite the Hall Effect sensor, producing a series of voltage pulses.
- The output pulses are at the same voltage level as the input (4.5 – 24 Vd.c.) with a frequency proportional to the flow rate. The output signal can be utilized by digital rate meters (see opposite page) totalizers or other electronic controllers.
- RotorFlow Indicators may be mounted with flow entering either port. Performance is optimized by positioning ports at the top of the unit, in a horizontal plane.

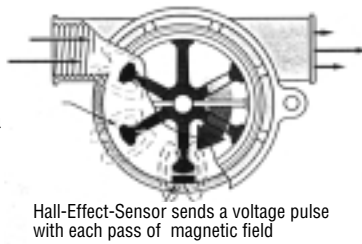

High Resolution Black Rotor

Ryton composite. Each of the six rotor arm is magnetized



Signal Output

Output signal for RFO Types is an on/off pulse of the DC voltage supplied to the unit, it is compatible with all digital logic families. Input voltage range is 4.5 to 24 Vd.c.

Frequency of the output pulse is proportional to the flow rate and ranges from approximately 25 Hz at low flow to 225 Hz at high flow. See order number for more information.

Low Flow

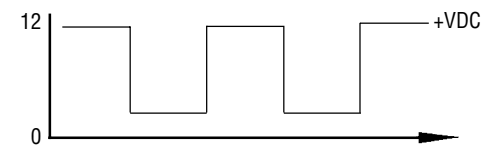

HighFlow

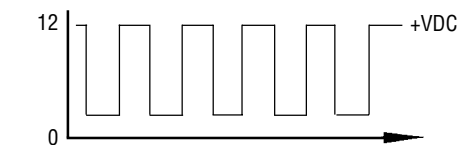

* With use of Low-Flow-Adapter supplied. See page 19 for more information.

Our Sensors caters to OEM needs with special configurations for potable water and enhanced chemical capabilities. Please consult factory for further details.

For dimensions see page RFS
Please consult factory for detailed flow rate / frequency curves.

Specifications

Wetted Materials	
Body	Polypropylene (Hydrolytically Stable, Glass Reinforced), Stainless Steel or Brass
Rotor Pin	Ceramic
Rotor	Ryton Composite, Colour: Black
Lens	Polysulfone
O-Ring	Buna N
Max. Operating Pressure	Polypropylene Body: 7 bar Metal Body: 14 bar
Max. Operating Temperature	Polypropylene Body: 80 °C Metal: 100 °C
Electronics (Both Bodies)	65 °C Ambient
Max. Viscosity	45 cSt
Input Power	4.5 to 24 Vd.c.
Output Signal	4.5 to 24 Vd.c. Pulse, Pulse Rate dependent on Flow Rate, Port Size and Range 0 to 10 V, 4 to 20mA available (RFA model), consult Sales Office
Max. Current Source Output	70 mA
Frequency Output Range	25 Hz (Low Flow) to 225 Hz (High Flow)
Electrical Termination	AWG 22 PVC-Jacketed Cable, Length 60 cm Colour Code: Red = + Vd.c., Black = Ground, White = Signal output
Typical Pressure Drop	See Graphs (Page RFS)

Order Numbers

Body Material	Port Size	Flow Ranges (l/min)		Output (Hz) Approximate	RFO	
		Low Range*	Standard Range		BSP	NPT
Polypropylene	1/4"	0.4 to 4.0 (±7%)	2.0 to 20.0 (±7%)	15-180	155421BSPP	155421
	1/2"	6.0 to 45.0 (±7%)	15.0 to 75.0 (±15%)	20-190	155481BSPP	155481
Brass	1/4"	0.4 to 4.0 (±7%)	2.0 to 20.0 (±7%)	15-180	156261BSPP	156261
	1/2"	6.0 to 45.0 (±7%)	15.0 to 75.0 (±15%)	20-190	156262BSPP	156262
	3/4"	---	7.5 to 112.5 (±15%)	15-130	180393BSPP	180393
	1"	---	15 to 225 (±15%)	15-130	181684BSPP	181684
Stainless Steel	9/16 - 18 UNF	0.4 to 4 (±7%)	2 to 20.0 (±7%)	15-180	N/A	165071
	1/2"	6 to 45 (±7%)	15.0 to 75.0 (±15%)	20-190	165075BSPP	165075
	3/4"	---	7.5 to 112.5 (±15%)	15-130	181686BSPP	181686
	1"	---	15 to 225 (±15%)	15-130	181687BSPP	181687

* With use of Low-Flow-Adaptor supplied, see page 22

RotorFlow - RFS Types Flow Setpoint Switching

RotorFlow Switches build an extra level of reliability and protection into your equipment. By principle of operation, the rotor cannot be deceived into indicating a positive flow situation when no flow actually exists. Once set to a desired actuation point, RotorFlow will switch to a 'no-flow' condition should the rotor stop for any reason.

Typical Applications

Protect expensive electronic equipment from coolant flow failure on:

- ▶ Lasers
- ▶ Medical Equipment
- ▶ X-Ray Tubes
- ▶ Computers
- ▶ Robotic Welding Equipment

Operating Principle

1. As liquid passes through the RotorFlow body the magnetic rotor spins at a rate proportional to flow. This causes a series of magnetic fields (the rotor vanes) to excite the Hall Effect Sensor, producing a series of voltage pulses.
2. RFS Type switches incorporate state-of-the-art circuitry to compare the frequency of incoming pulses to an adjustable, preset frequency. When the pulse rate meets or exceeds the preset value, the SPDT relay closes. When the pulse rate falls below the preset value, the output relay opens. This unique design eliminates the possibility of a RotorFlow switch from remaining in a 'switch actuated' mode, if the rotor jams accidentally.
3. RotorFlow Indicators may be mounted with flow entering either port. Performance is optimized by positioning ports at the top of the unit, in a horizontal plane.

Specifications

Wetted Materials	
Body	Polypropylene, Brass, S Steel (Hydrolytically Stable, Glass Reinforced)
Rotor Pin	Ceramic
Rotor	Ryton Composite, Colour: Black
Lens	Polysulfone
O-Ring	Buna N
Max. Operating Pressure	Polypropylene Body: 7 bar Metal Body: 14 bar
Max. Operating Temperature	Polypropylene Body: 80 °C Metal Body: 100 °C
Electronics	65°C Ambient
Max. Viscosity	45 cst
Input Power	12 Vd.c., 24 Vd.c. or 110 Va.c. (230 V a.c. on request)
Relay Contact Ratings (SPDT)	1A, 24 Vd.c. Resistive 0,5 A, 110 Va.c. (230 V a.c. on request)
Repeatability	2% max. Deviation
Set Point Accuracy (Factory Set)	± 5%
Hysteresis	max. 15%
Electrical Termination	22 AWG PVC-Jacketed Cable, Length 60 cm, Colour Code: Red = +Va.c./Vd.c., Black = Ground, White = N.O., Brown = N.C., Green = Common
Typical Pressure Drop:	See Graphs

Order Numbers

Body Material	Port Size	Flow Ranges (l/min)		Input Power	Order Number	
		Low Range*	Standard Range		BSP	NPT
Polypropylene	1/4"	0.4 to 4.0	2.0 to 20.0	12 VDC 24 VDC 110 VAC	155424BSPP 155425BSPP 155876BSPP	155424 155425 155876
	1/2"	6.0 to 45.0	15.0 to 75.0	12 VDC 24 VDC 110 VAC	155484BSPP 155485BSPP 155886BSPP	155484 155485 155886
Brass	1/4"	0.4 to 4.0	2.0 to 20.0	12 VDC 24 VDC 110 VAC	156264BSPP 156265BSPP 156266BSPP	156264 156265 156266
	1/2"	6.0 to 45.0	15.0 to 75.0	12 VDC 24 VDC 110 VAC	156267BSPP 156268BSPP 156269BSPP	156267 156268 156269
	3/4"	---	7.5 to 112.5	12 VDC 24 VDC 110 VAC	180394BSPP 180395BSPP 180396BSPP	180394 180395 180396
	1"	---	15 to 225	24 VDC 110 VAC	181688BSPP 181689BSPP	181688 181689
Stainless Steel	9/16" - 18UNF	0.4 to 4	2.0 to 20.0	24 VDC 110 VAC	N/A N/A	165073 165074
	1/2"	6 to 45	15.0 to 75.0	24 VDC 110VAC	165077BSPP 165078BSPP	165077 165078
	3/4"	---	7.5 to 112.5	24 VDC 110 VAC	181691BSPP 181692BSPP	181691 181692
	1"	---	15 to 225	24 VDC 110 VAC	181693BSPP 181694BSPP	181693 181694

* With use of Low-Flow-Adapter supplied, see page 22.

Switch Set Point Calibration With LED Signal (RFS Type)

With the unit installed in the line and power supplied, complete the following steps to calibrate switch actuation point with proper flow rate. A small flat-blade screwdriver is the only tool required.

1. Adjust liquid flow in the line to the rate at which switch actuation is desired.
2. Insert screwdriver into opening on backside of housing and fit blade into the potentiometer adjustment screw inside.
3. If LED is not illuminated, slowly turn screwdriver counterclockwise and stop as soon as LED illuminates.
4. If LED is illuminated, turn screwdriver clockwise until LED light goes out. Then, slowly turn screwdriver counterclockwise and stop as soon as LED illuminates.

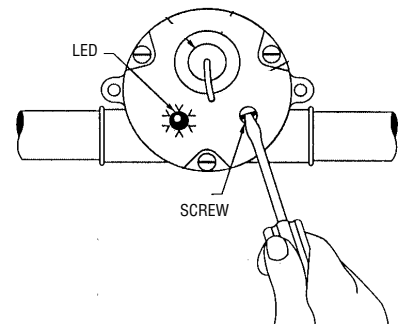

Pressure Drop Typical RFO and RFS Types

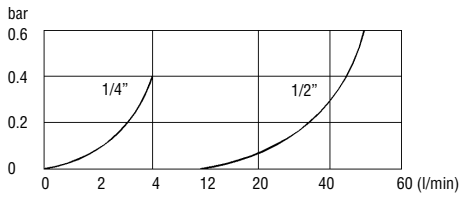
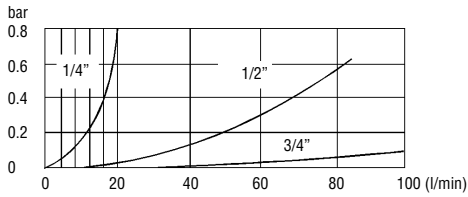

Dimensions - RFA, RFO, RFS

Polypropylene Bodies

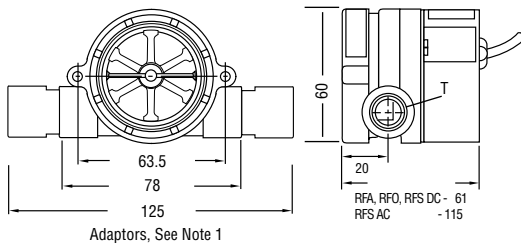

Metal Bodies

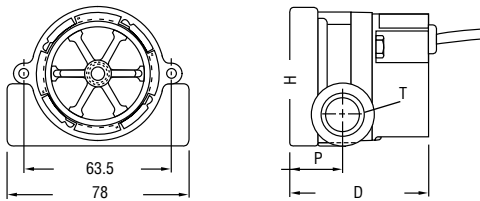

T	W	H	D		P
			DC models	AC models	
1/4	77	60	61	114	20
1/2	77	60	61	114	22
3/4	100	66	75	121	27
1	100	66	75	121	27

Notes:

- Adaptors are supplied fitted to plastic units, sealed using Teflon (PTFE) tape.
- If NPT thread is required for plastic units discard adaptor.