

CODEUR INCREMENTAL INCREMENTAL ENCODER INKREMENTALE DREHGEBER

GZT4

Le **plus compacte** des axes creux Ø40mm

Montage aisé par lame flexible d'anti-rotation

Applications:
micro-robotique, moteurs CC de faible puissance, cisailles...

The **most compact** Ø 40mm hollow shaft encoder

Easy mounting by flexible anti-rotation blade

Applications:
micro-robotics, DC motors, shears...

Der **kompakteste** 40mm Ø Drehgeber mit Hohlwelle

Leichte Montage durch flexible Drehmomentfeder

Anwendung:
Micro-Robotik, DC Motoren, Scheren...

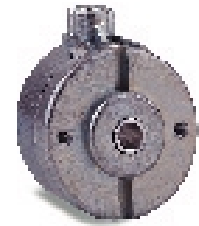

CARACTERISTIQUES SPECIFICATIONS KENNDATEN

DIMENSIONS DIMENSIONS ABMESSUNGEN

• CAPOT COVER DECKEL	Zamac Zinc alloy Zink-Druckguss	• VITESSE DE ROTATION MAX. SPEED MAX. DREHZAHL	12 000 min ⁻¹ 12 000 min ⁻¹ 12 000 min ⁻¹
• EMBASE BODY GEHÄUSE	Zamac Zinc alloy Zink-Druckguss	• CHARGE RADIALE MAX. RADIAL SHAFT LOADING MAX. WELLENBEL. RADIAL	20 N 20 N 20 N
• AXE SHAFT WELLE	Aluminium Aluminium Aluminium	• CHARGE AXIALE MAX. AXIAL SHAFT LOADING MAX. WELLENBEL. AXIAL	10 N 10 N 10 N
• COUPLE TORQUE DREHMOMENT	0,25 Ncm 0,25 Ncm 0,25 Ncm	• MOMENT D'INERTIE INERTIA TRÄGHEITSMOMENT	5 gcm ² 5 gcm ² 5 gcm ²
• POIDS WEIGHT GEWICHT	100 g 100 g 100 g	• ETANCHEITE PROTECTION SCHUTZART	IP 52 IP 52 IP 52

3R

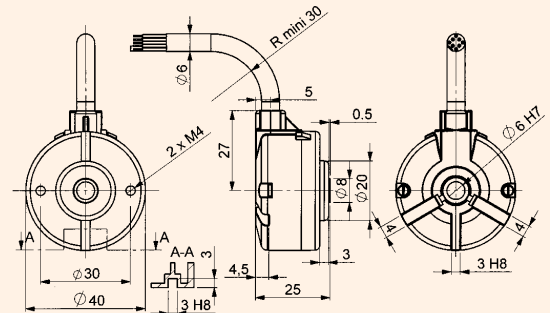

ACCESSOIRES - ACCESSORIES - ZUBEHÖR
P. 31

REFERENCES DE COMMANDE ORDERING CODE BESTELLBEZEICHNUNG

Ex. de commande / Ordering example / Bestellbeispiel : **GZT406 293R/1024**

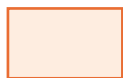

GZT4



Axe Ø
Shaft Ø
Wellen Ø

06 = 6 mm



Etages de sortie
Output circuit
Ausgangsstufen

2 = 5 V RS422
5 = 11-30 V Driver
9 = 5-24 V Driver



Signaux de sortie
Output signals
Signalausgang

9= A, \bar{A} , B, \bar{B} , 0, $\bar{0}$
7= A, \bar{A} , B, \bar{B}
5= A, \bar{A}
A= top 0 sur A
Index gated on A
Nullimpuls verknüpft mit A
N= top 0 non-calibré
Index ungated
Nullimpuls unverknüpft



Connectique
Connection
Anschluss

3R



Impulsions/tr
Pulses/revolution
Schritte/Umdr.

1024 max



Meyer Industrie-Electronic GmbH - MEYLE

Carl-Bosch-Straße 8 Tel.: (+49) 05481-9385-0 Internet: www.meyle.de
49525 Lengerich/Germany Fax: (+49) 05481-9385-12 E-Mail: sales@meyle.de