

# Incremental Shaft Encoders Type RI 76 TD with Hollow Shaft



NUMBER OF PULSES

- Through shaft with up to diameter 42 mm
- Short overall length with an outside diameter of only 76 mm
- Easy installation by means of clamping ring
- Operating temperature up to 100 °C
- Application e.g.:
  - motors
  - printing machines
  - lifts

50 / 100 / 250 / 300 / 500 / 600 / 900 / 1,000 / 1,024 / 1500 / 2,048 / 2,500 / 3,072 / 4096 / 5,000 / 9,000 / 10,000

Other numbers of pulses available on request

## TECHNICAL DATA mechanical

Shaft fixation	clamping ring, front or rear
Coupling	stator coupling (spring plate)
Shaft diameter	15...42 mm (Available: 15, 16, 18, 20, 24, 25, 27, 28, 30, 32, 38, 40, 42 mm also 5/8", 1 1/8", 3/4")
Minimum length of mounting shaft	
Front clamping ring	32 mm with $\varnothing$ 15...30, 35 mm with $\varnothing$ > 30...42
Rear clamping ring	corresponding to total length of encoder
Max. parallel shaft misalignment	
With flexible stator coupling A (flexible)	$\pm$ 2.0 mm axial, $\pm$ 0.15 mm radial
With 1 x flexible stator coupling N (torsionally rigid)	$\pm$ 0.5 mm axial, $\pm$ 0.3 mm radial
With 2 x flexible stator coupling N (torsionally rigid)	$\pm$ 0.3 mm axial, $\pm$ 0.2 mm radial
Absolute maximum speed	at 70° C and IP 64: 3,600 RPM for $\varnothing$ 15...25 at 70° C and IP 64: 1,800 RPM for $\varnothing$ > 25...42 at 70° C and IP 40: 6,000 RPM for $\varnothing$ 15...42 at 100° C always: 1,800 RPM for $\varnothing$ 15...42
Torque	3...10 Ncm (depending on version)
Moment of inertia	140...420 gcm <sup>2</sup> (depending on version)
Protection class (EN 60529)	Housing IP 50, bearings IP 40
Option:	Housing IP 65, bearings IP 64
Operating temperature	-25 ...+100 °C
Storage temperature	-25...+100 °C
Vibration proof (IEC 68-2-6)	10 g = 100 m/s <sup>2</sup> (10 ... 2,000 Hz)
Shock resistance (IEC 68-2-27)	100 g = 1,000 m/s <sup>2</sup> (6 ms)
Type of connection	1.5 m cable <sup>1)</sup> radial
Housing	aluminium
Weight	320 - 580 g (depending on version)

<sup>1)</sup> Other cable length on request

## TECHNICAL DATA electrical

General design	as per DIN EN 61010, protection class III, contamination level 2, overvoltage class II	
Supply voltage (SELV)	with RS 422 (R, T):	5 VDC $\pm$ 10 %
	with push-pull (K, I):	10 ... 30 VDC <sup>1)</sup>
Power consumption	60 mA (5 VDC), 60 mA (10 VDC), 35 mA (24 VDC)	
Standard-Output versions <sup>2)</sup>	RS 422 (R):	A, B, N, $\bar{A}$ , $\bar{B}$ , $\bar{N}$ , $\bar{Alarm}$
	RS 422 (T):	A, B, N, $\bar{A}$ , $\bar{B}$ , $\bar{N}$ , Sense
	push-pull (K):	A, B, N, $\bar{Alarm}$
	push-pull complementary (I):	A, B, N, $\bar{A}$ , $\bar{B}$ , $\bar{N}$ , $\bar{Alarm}$

<sup>1)</sup> Pole protection with supply voltage 10 ... 30 VDC

<sup>2)</sup> Output description and technical data see section „output“.

# Incremental Shaft Encoders Type RI 76 TD with Hollow Shaft

## DIMENSIONED DRAWING

### WITH SPRING PLATE "RIGID"

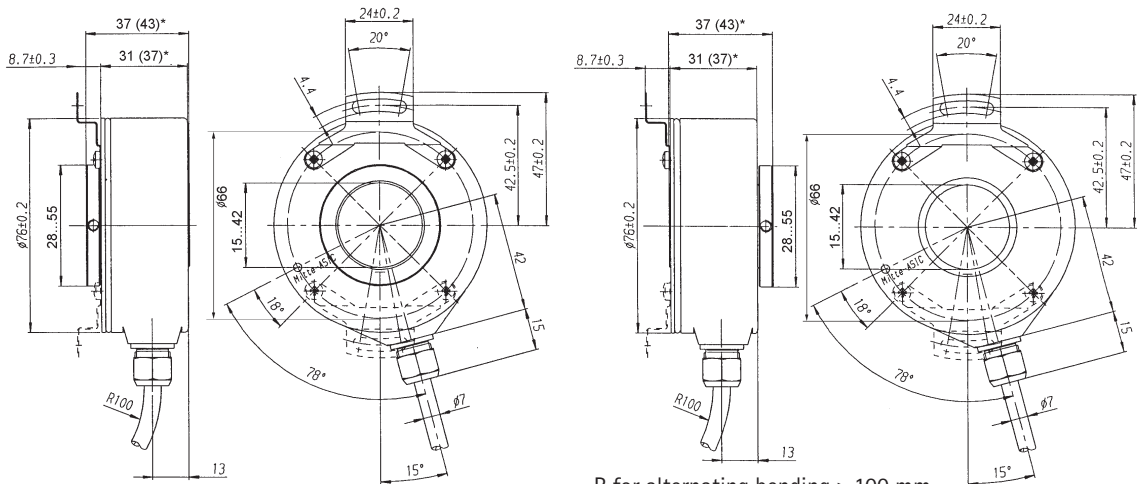

\* Values in brackets for shaft diameter > 30  
Diameter of connection shaft 15g8...42g8

R for alternating bending > 100 mm  
R for permanent bending > 40 mm

### WITH SPRING PLATE "FLEXIBLE"

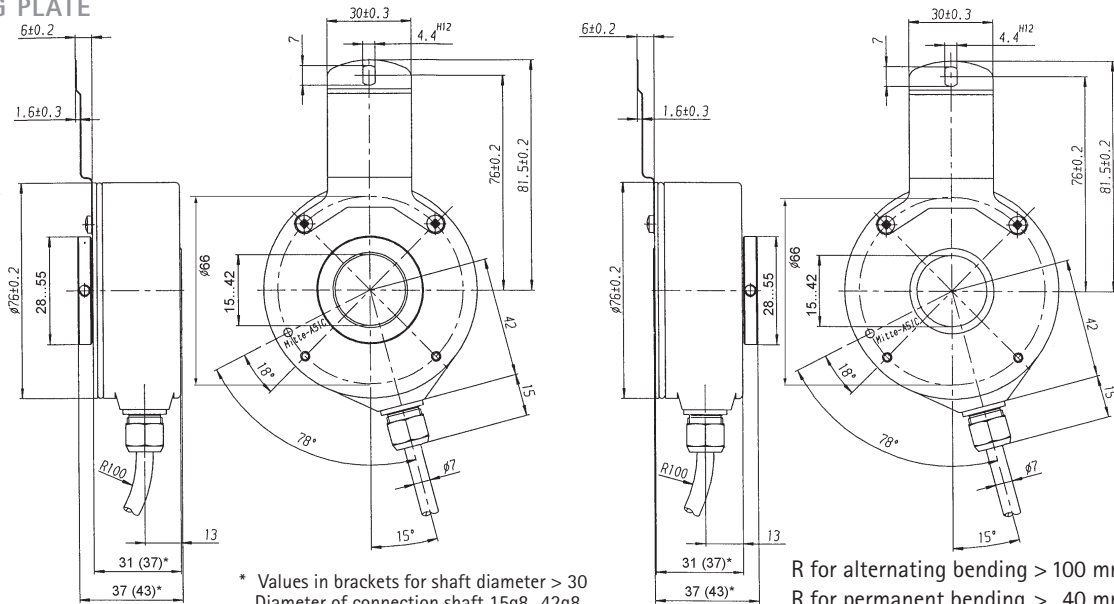

\* Values in brackets for shaft diameter > 30  
Diameter of connection shaft 15g8...42g8

R for alternating bending > 100 mm  
R for permanent bending > 40 mm

## SHAFT CONNECTION

Shaft fixing is done through a clamping ring either on the flange or cap side. As a rule, flange side clamping is better for smaller motors as the available shaft stub is correspondingly shorter. On the other hand, cap side clamping is easier when there is sufficient shaft length available.

## MOUNTING NECESSITIES

In order to compensate for axial and radial shaft eccentricity as well as any angle offset, the encoder flange may not be rigidly mounted. Please mount the flange with a flexible stator coupling (e.g. spring plate) as torque support. There are two flexible mounting plates:

- A flexible spring plate (A) for higher levels of play and lower requirements for accuracy.
- A rigid spring plate (N) for reduced play and rigid connection with reduced swing angle. This is suitable in the case of higher accuracy and dynamics requirements.

# Incremental Shaft Encoders Type RI 76 TD with Hollow Shaft

## CONNECTION DIAGRAM CABLE TPE

Colour (TPE)	Output circuit			
	RS 422 + Sense (T)	RS 422 + Alarm (R)	push-pull (K)	push-pull complementary (I)
brown	Channel A	Channel A	Channel A	Channel A
green	Channel $\bar{A}$	Channel $\bar{A}$		Channel $\bar{A}$
grey	Channel B	Channel B	Channel B	Channel B
pink	Channel $\bar{B}$	Channel $\bar{B}$		Channel $\bar{B}$
red	Channel N	Channel N	Channel N	Channel N
black	Channel $\bar{N}$	Channel $\bar{N}$		Channel $\bar{N}$
violet (white) <sup>2)</sup>	Sense GND	$\bar{\text{Alarm}}$	$\bar{\text{Alarm}}$	$\bar{\text{Alarm}}$
blue	Sense $V_{CC}$	Sense $V_{CC}$		Sense $V_{CC}$
brown/green	5 VDC=	5/10 ... 30 VDC=	10 ... 30 VDC=	10 ... 30 VDC=
white/green	GND	GND	GND	GND
Screen <sup>1)</sup>	Screen <sup>1)</sup>	Screen <sup>1)</sup>	Screen <sup>1)</sup>	Screen <sup>1)</sup>

<sup>1)</sup> connected to housing

<sup>2)</sup> white for RS 422 + Sense (T)

## ACCESSORIES

Spring plate, flexible	Ordering code 1 533 079
Spring plate, rigid	Ordering code 1 533 078

## ORDERING DATA

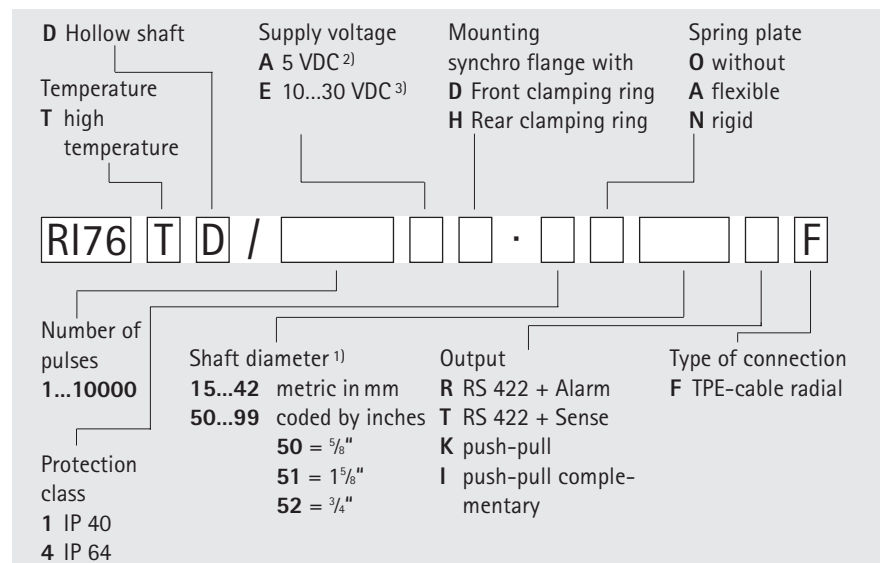

<sup>1)</sup>Available with front clamping ring and IP 40: 15, **20**, **24**, 25, 27, 28, 30, 38, 40, 42, 50 (5/8"), 51 (15/16")

Available with front clamping ring and IP 64: **15**, 16, 18, **20**, 24, **25**, 27, 28, 30, 32, **38**, **40**, **42**, 50 (5/8"), 51 (15/16"), 52 (3/4")

Available with rear clamping ring and IP 40: 25, 28, 30, 32, 38, 40, 42

Available with rear clamping ring and IP 64: 20, **25**, 30, 32, 38, 40, **42**

Bold printed: preferred versions

Others: please request delivery time

<sup>2)</sup> only with output R, T, K

<sup>3)</sup> only with output R, K, I