

Industrial types



NUMBER OF PULSES

- Miniature industry standard encoder for high numbers of pulses
- High reliability
- Application e.g.:
 - CNC axles
 - Machine tools
 - Robots
 - Special purpose machines
 - High-speed winding machines

5 / 10 / 20 / 25 / 28 / 32 / 50 / 60 / 72 / 100 / 128 / 144 / 200 / 250 / 256 / 288 / 300 / 360 / 400 / 500 / 512 / 600 / 720 / 900 / 1,000 / 1,024 / 1,250 / 1,500 / 2,000 / 2,048 / 2,500 / 3,000 / 3,600

Other numbers of pulses available on request

TECHNICAL DATA mechanical

Shaft diameter	6 mm / 6,35 mm
Absolute max. shaft load	radial 30 N / axial 15 N (6.5/3.3 lbs)
Absolute maximum speed	max. 10,000 RPM
Torque	≤ 0.3 Ncm
Moment of inertia	ca. 2.8 gcm ²
Protection class (EN 60529)	Housing IP 64, bearings IP 64
Operating temperature	-10 ... +70 °C
Storage temperature	-25 ... +85 °C
Vibration performance	100 m/s ² (10 ... 2,000 Hz)
Shock resistance	1,000 m/s ² (6 ms)
Type of connection	1.5 m cable or connector, axial or radial ¹⁾
Housing	aluminium
Flange	S = synchro flange, R = round flange
Wight	80 g approx.
Bearing life	1 x 10 ¹⁰ revolutions (typ.) at 35% of full rated shaft load 1 x 10 ⁹ revolutions (typ.) at 75% of full rated shaft load 1 x 10 ⁸ revolutions (typ.) at 100% of full rated shaft load For example 30,000 h at 6,000 RPM with a 2 lb radial load

¹⁾ Other cable length on request

TECHNICAL DATA electrical

General design	as per DIN VDE 0160, protection class III, contamination level 2, overvoltage class II	
Supply voltage (SELV)	with RS 422 (R, T):	5 VDC ± 10 %
	with push-pull (K, I):	10 ... 30 VDC ¹⁾
Power consumption	40 mA (5 VDC), 60 mA (10 VDC), 30 mA (24 VDC)	
Standard-Output versions ²⁾	RS 422 (R):	A, B, N, \bar{A} , \bar{B} , \bar{N} , Alarm
	RS 422 (T):	A, B, N, \bar{A} , \bar{B} , \bar{N} , Sense
	push-pull (K):	A, B, N, \bar{A} , \bar{N}
	push-pull complementary (I):	A, B, N, \bar{A} , \bar{B} , \bar{N} , Alarm

¹⁾ Pole protection

²⁾ Output description and technical data see section „output“.

Incremental Shaft Encoders Industrial types

Type RI 36

DIMENSIONED DRAWINGS

Synchro flange

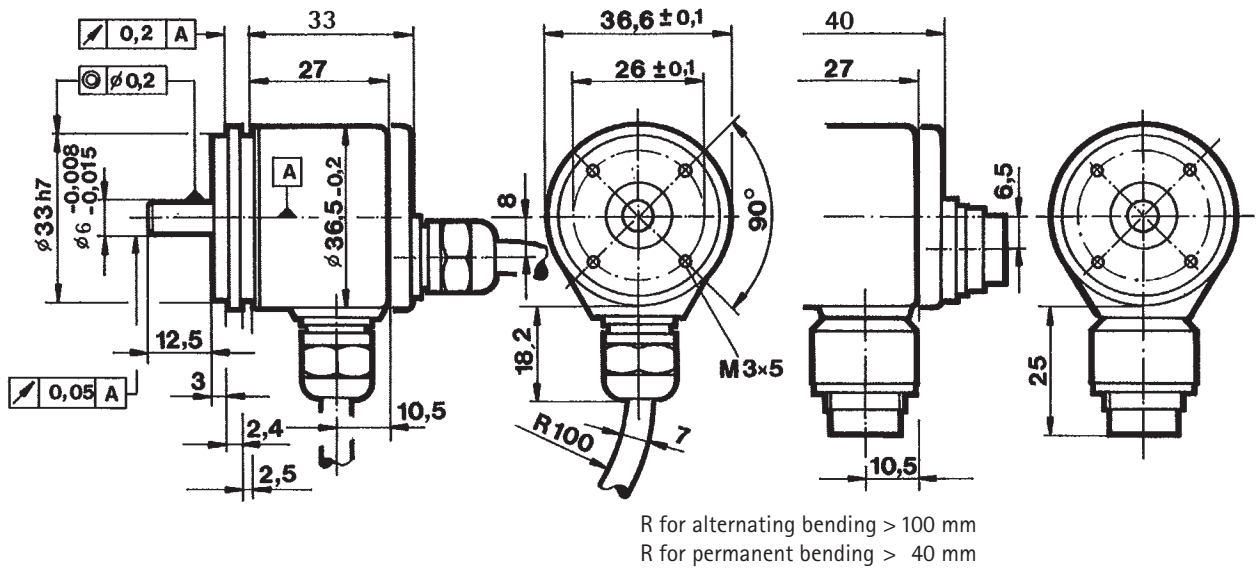

Round flange

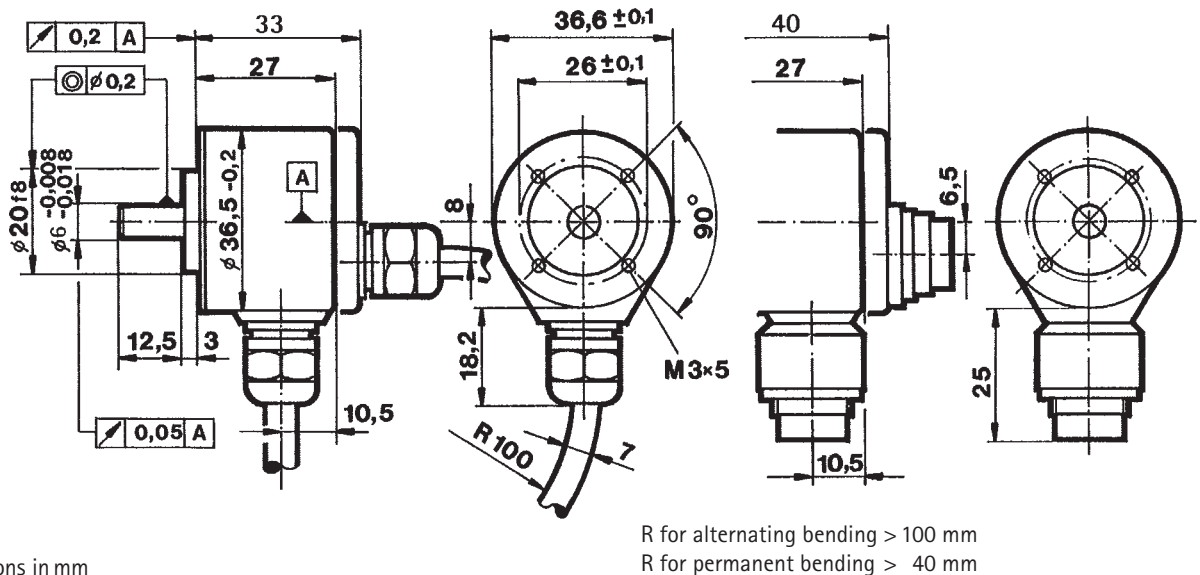

Dimensions in mm

CONNECTOR 6 POLE (BINDER)

Description (push-pull)	Pin
10 ... 30 VDC	1
Channel A	2
Channel N	3
Channel B	4
Alarm	5
GND	6

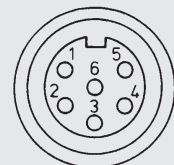

Industrial types

CONNECTION DIAGRAM

Cable PVC (A, B)	Lead Ø	Output (R, T)	push-pull (K)	push-pull complementary (I)
red	0.5	5 VDC=	10...30 VDC=	10...30 VDC=
yellow/red	0.14	Sense V _{CC}		Sense V _{CC}
white	0.14	Channel A	Channel A	Channel \bar{A}
white/brown	0.14	Channel \bar{A}		Channel A
green	0.14	Channel B	Channel B	Channel \bar{B}
green/brown	0.14	Channel \bar{B}		Channel B
yellow	0.14	Channel N	Channel N	Channel N
yellow/brown	0.14	Channel \bar{N}		Channel \bar{N}
black	0.5	GND	GND	GND
yellow/black	0.14	Alarm/Sense GND ¹⁾	Alarm	Alarm
Screen ²⁾		Screen ²⁾	Screen ²⁾	Screen ²⁾

¹⁾ depending on ordering code

²⁾ connected to housing

ORDERING DATA

O standard	Supply voltage	Type of flange	Shaft diameter
	A 5 VDC	S synchro flange	1 6 mm
	E 10 ... 30 VDC (only push-pull)	R round flange	5 6.35 mm

RI36	-	0	/				.	3			
Number of pulses		Protection class		Output			Type of connection				
5 ... 3,600		3 IP 64		T RS 422 + Sense K push-pull short circuit proof			A cable axial B cable radial N BINDER ¹⁾ , 6 pole, axial (only push-pull) J BINDER*, 6 pole, radial (only push-pull)				
				R RS 422 + Alarm I push-pull complementary							

¹⁾ encoder connector with pins