

GENERAL/OVERVIEW

Introduction

Description

The optical rotary encoder is an angular position sensor. It is made source of light, light emitting diode (or LED), a receptor and a disk rotating in between. The optical disk with dark and clear radial lines is mounted on the rotating shaft of the encoder. Most of the disks used by Meyle are Polyfass (Mylar-Mica composite) and are unbreakable (see photo). The light from the LED crosses the lines on the disk and creates an analogical signal in the receptor, which is later amplified and could be converted in either square-wave or sine-cosine signals. All Meyle encoders use the differential reading, helping to compensate the reduction of the amplitude of the signals due to higher temperature, age, wearing of the bearings, etc.

Incremental encoders simply count the number of pulses engraved on the disk and in case of power shut-down, it is necessary to find out the origin at every new start.

Single-turn absolute encoders determine their position at all times using a single code in a given single revolution, even if there is no reference measurement.

Multi-turn absolute encoders provide in addition a reading of the position within the revolution and is capable of counting the number of turns made.

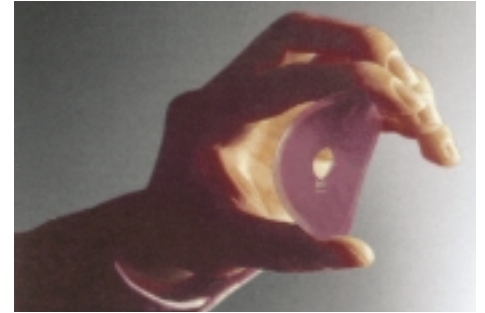

Applications

Stop dog positioning

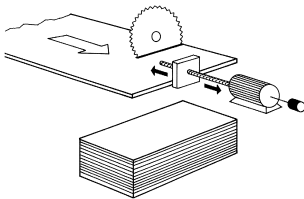

Workpiece lengthmeasurement system with opto electric and encoder

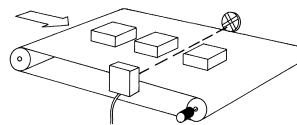

Crosstable positioning

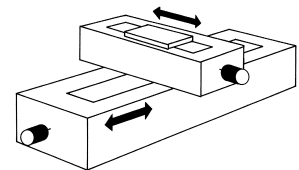

Valve position control

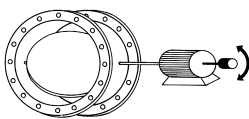

Length dimension with measuring wheel

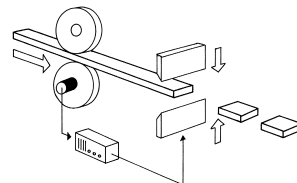

Lengthmeasuring of textile or paper rolls

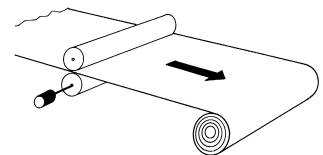

Roboter axis control

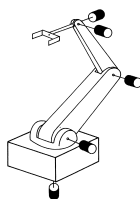

Fork hight measuring at fork trucks

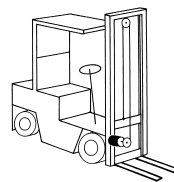

Positioning at CNC-tooling-machines

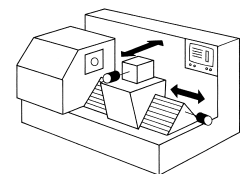

Tensile stress control

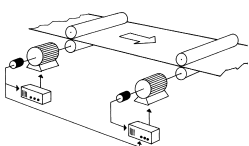

Control of transport vehicles

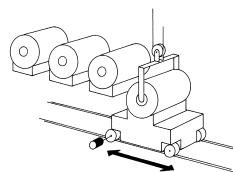

Adjustment of lift platforms

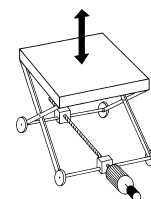

GENERAL/OVERVIEW

General

Conformity:

All Meyle encoders fully comply with the CE-regulations and are intensively tested in our EMC laboratories. They

conform to CE requirements according to EN 50082-2, EN 50081-2 and EN 55011 class B.

High quality of signals:

All encoders from Meyle, are equipped with ageing and temperature compensation to ensure a long term and stable signal also after many years of operation.

Ageing compensation:

Each LED source will inevitably lose its power over a period of time. As a result, the output signal degrades. The phase shift between channel A and B of 90° becomes

less and less. The direction of rotation may no longer be detected. Properly by the control, a special electronic circuit, which is built in the specific ASIC prevents this effect.

Signals of a new encoder or encoders with ageing compensation:

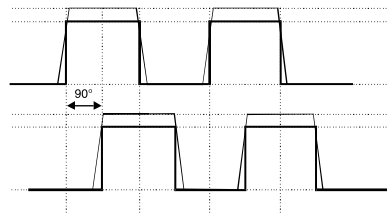

Signals of an older encoder without ageing compensation:

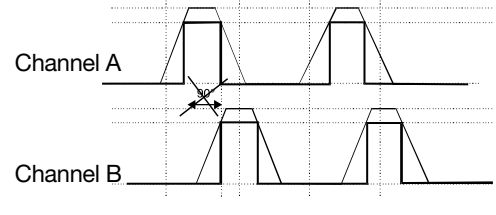

Benefit: The ageing compensation circuit ensures the same signal, even after many years of operating time. The down time of

machines will be reduced dramatically and the reliability is increased.

Temperature compensation:

This specialised circuit ensures that the quality of the signal will stay on the same high level over the whole working temperature range.

Benefit:

The positioning accuracy of a machine will not be affected by temperature changes.

Environmental conditions:

A significant influence on the lifetime of the encoder is set by the environment in which the encoder is operating, e.g.:

- The ambient temperature
- The expected shaft load
- The possible grade of dust/dirt and humidity/liquids

The support design and the use of high quality components makes our encoders suitable for applications in **rough conditions**. Many references such as from Bosch, Siemens, Bombardier and other customers proof these high requirements.

Temperature:

Definition according to DIN standards 32 878

Working temperature:

Is defined as the environmental temperature, in which the encoder will produce the signals defined in the data sheets.

Operating temperature:

Is defined as the environmental temperature which the encoder can withstand without getting damaged.

GENERAL/OVERVIEW

General

Dirt/dust and humidity/water:

The IP classification according to EN 60529 describes how the encoder is protected against particles and water. It is described as an abbreviation "IP" followed by two numbers.

The first digit defines the size of the particles. The higher the number the smaller the particles.

The second digit defines the resistance against water. The higher the number, the higher the water pressure can be.

Our encoders have a protection up to IP 67. These two tables summarise the most used IP ratings:

Protection against particles (first digit):

0	not protected
1	protected against particles 50 mm and larger
2	protected against particles 12,5 mm and larger
3	protected against particles 2,5 mm and larger
4	protected against particles 1,0 mm and larger
5	protected against dust
6	dust proof

Protection against water (second digit):

0	not protected
1	protected against vertically falling drops of water
2	protected against falling drops of water up to 15° from vertical
3	protected against water sprayed up to 60° from vertical
4	protected against water sprayed from all directions, limited ingress permitted
5	protected against low pressure jets from all directions, limited ingress permitted
6	protected against strong jets of water, e.g. for use on ship decks, limited ingress permitted
7	protection against the effects of immersion between 15 cm and 1 m
8	protected against long periods of immersion under pressure

Designation of colours to DIN standard 757

abbreviation	colour
BK	black
BN	brown
RD	red
OG	orange
YE	yellow
GN	green
BU	blue

VT	violet
GY	grey
WH	white
PK	pink
GD	gold
TQ	turquoise
SR	silver

Shaft Load:

Due to misalignment and other mechanical influences from outside, the shaft of the encoder is exposed to a number of different loads. This has a direct impact on the lifetime of the ball bearings and also on the electrical signal itself. If there is an overload there will be an early wear and in the worst case it will lead to a failure of the unit and to a destruction of the optical system inside.

For shaft encoders the maximal radial and axial load should not be exceeded. It is highly recommended to use a coupling between the encoder shaft and the drive shaft, see also the accessories and the mounting suggestions.

In the technical data sheets of the encoders, typical values for the radial and axial load at the shaft end are listed. This is based on the lifetime of the ball bearing, the speed, the mechanical load and the temperature.

To easily find the lifetime for the specific application the following diagrams can be used. All of the diagrams are based on the following parameters:

- 60° C environmental temperature
- The axial load is always half the load compared to the radial load



GENERAL/OVERVIEW

General

Type series 58 mm diameter

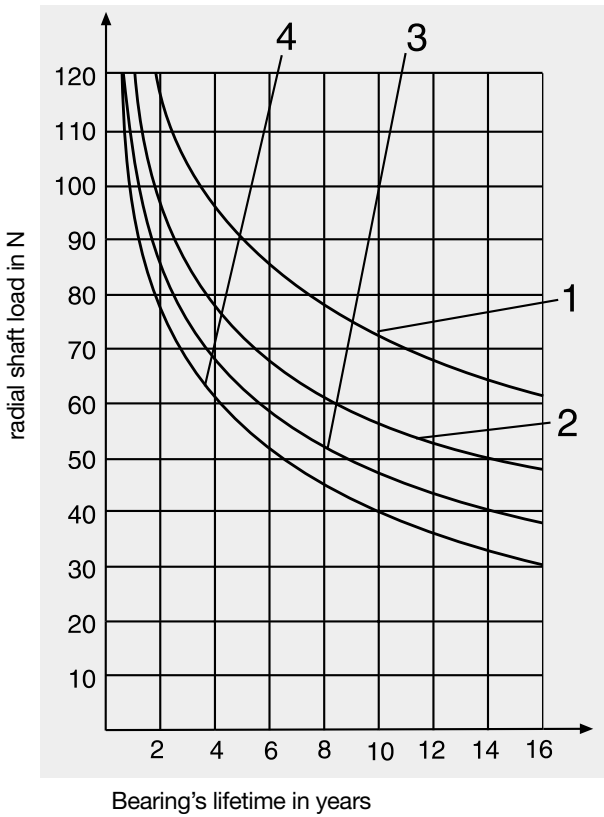

Type series 90 mm diameter

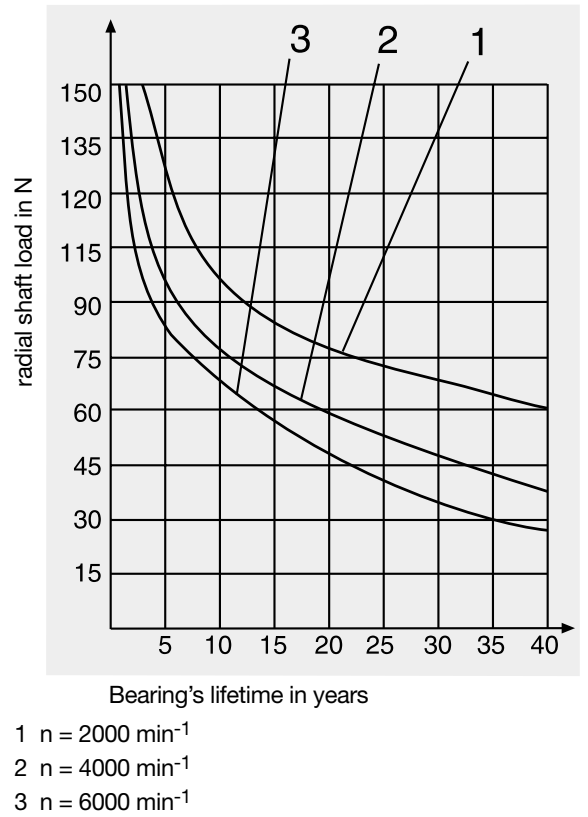

Incremental encoder

Assembly and function:

Meyle encoders operate on an electro-optical scanning principle.

A disk with a radial grating of lines and gaps rotates between a light source (mostly a LED) and a receiver which produces a sine wave signal proportional to the light received.

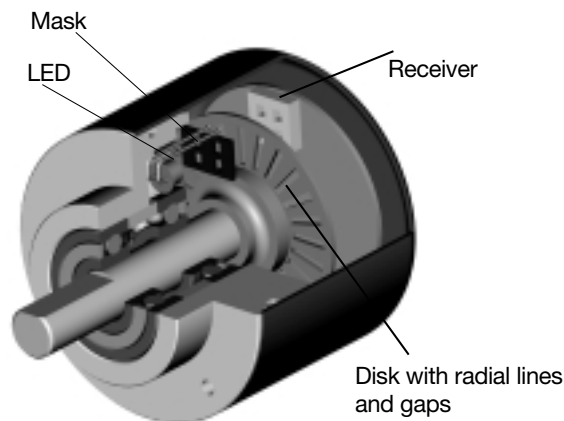

Processing of the signals:

The sine wave signals are processed further in an electronic circuitry, usually a specific ASIC. This is necessary because most controllers controls (like e.g. counters) require digital signals with a certain voltage

level. For that the signals are pre-processed in the encoder. The pre-processed signals are transmitted by the output circuit depending on the application.



GENERAL/OVERVIEW

General

Selecting an incremental encoder:

Number of channels:

When selecting the encoder, following parameters should be considered in addition to the topic mentioned on page 8–10.

Encoders with one output channel

Encoders with one output channel are used where no direction sensing is needed, e.g.

speed control or length measuring.

Encoders with two output channels

Applications, where the direction of a rotation should be sensed, e.g. positioning, require encoders with two channels A and B being shifted 90° out of phase.

By detecting the phase shift, the direction can be located.

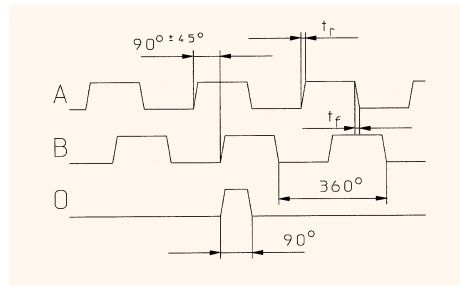

- Shaft turning clockwise, top-view of shaft
 - Inverted signals available
 - 0-pulse is linked to AND with channel A and B
- t_r = rise time
 t_f = fall time

Encoders with three output channels

In addition to the two channels A and B there is a zero signal available, that appears once per turn. This can be used e.g. as a

reference signal during the first revolution after power up.

Multiplication of pulses:

The resolution of a two channel encoder can be multiplied by two or four using a special edge detecting.

An encoder with physically 5000 pulses per revolution can generate 20000 pulses per revolution using this technique

Inverted signals:

When used in environments, with a lot of electrical noise and/or if very long cable distances are required, we recommend to use encoders with inverted (complementary)

signals. These signals are always available with output circuits of the RS 422 type and sine wave outputs. Meyle also offers them for push-pull outputs.

Resolution:

Example: An encoder is equipped with a measuring wheel. Every revolution corresponds to a distance of 200 mm (circumference). The accuracy should be 0,1 mm. What is the required resolution (ppr)?

Given: Circumference of the measuring wheel: $U = 200$ [mm]
Accuracy of the system: $G = 0,1$ [mm]
Wanted: Resolution of the encoder: $A = ?$ [pulses/resolution]

$$\text{resolution} = \frac{\text{Circumference}}{\text{Accuracy}} = \frac{U}{G}$$

The required resolution would be 2000 ppr (pulses per revolution).

GENERAL/OVERVIEW

General

Pulse frequency:

The required pulse frequency can be calculated. This is based on the number of pulses per turn (ppr) and the speed (rpm). The max. pulse frequency is listed for each encoder. Usually it is 300 kHz. Meyle also offers high resolution encoders with a pulse frequency of up to 800 kHz.

Example

of how to calculate the required pulse frequency f_{max} :

Given: Speed $n = 3000 \text{ min}^{-1}$

Resolution of the encoder

$R = 1000 \text{ ppr}$

$$f_{max} = \frac{n \times A}{60}$$

The required pulse frequency is 50 kHz. Now you can compare this result with the data of the encoder you would like to choose.

This diagram can be used for the most common resolutions as a quick guide:

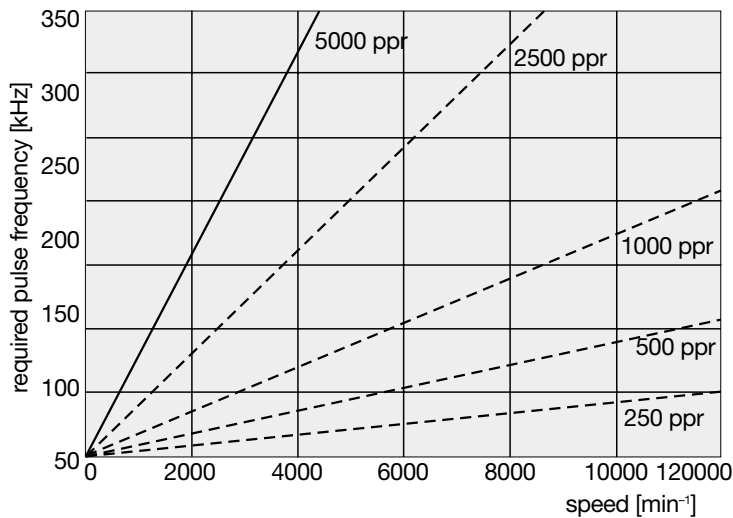

Outputs and voltage supplies (overview):

Meyle offers a wide range of possible outputs and voltage supplies for any application.

Output	Inverted signals	Voltage supply
RS 422	Yes	5 V DC
RS 422	Yes	10 ... 30 V DC or 5 ... 30 V DC
Push Pull output	No	10 ... 30 V DC or 5 ... 30 V DC
Push Pull output	Yes	10 ... 30 V DC or 5 ... 30 V DC
Sine wave voltage output	Yes	5 V DC
Sine wave voltage output	Yes	10 ... 30 VDC

If the encoder is used in an environment with strong electrical noise and long cables we highly recommend the use of inverted signals.

Sensor outputs:

The sensor outputs are used if the distance from the encoder to the control unit is very long and the voltage supply at the encoder could drop due to this long distance. The input impedance of the sensor inputs (Controller) is very high, and the voltage drop

on the sensor output line is almost zero. Due to this it is possible to detect the actual supply voltage of the encoder (e.g. 4,2 V instead of 5 V). Based on this information the controller will increase the voltage supply to e.g. 5,8 V.



GENERAL/OVERVIEW

General

Digital outputs:

The sine wave signal from the optical system is first digitised to have square wave signals available.

- Shaft turning clockwise, top view of shaft
- Inverted signals are available
- 0-pulse is linked to AND with channel A and B

To transmit the signals there are two possible outputs available. RS 422 (TTL compatible) or push-pull (covers PNP or NPN). For choosing the suitable output for the application the following points have to be considered:

- The corresponding unit / controller the encoder will be connected to

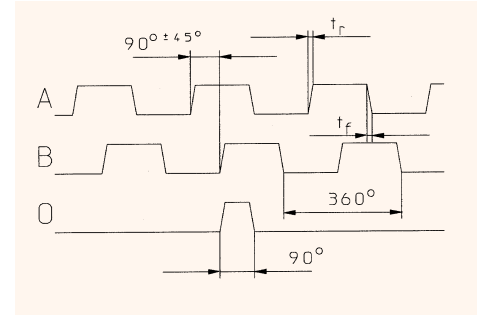

- The distance from the encoder to the receiver unit
- The sensitivity against electrical noise or other interferences.

Output circuit and recommended input circuit RS 422:

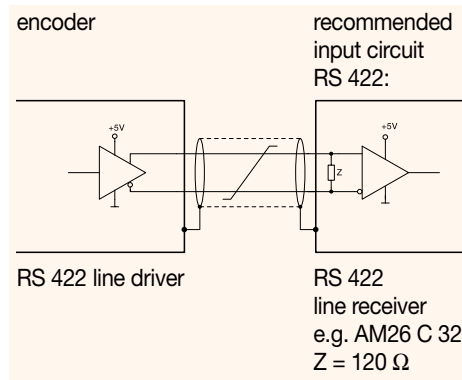

Push-pull:

Push-pull outputs are suitable for count interface cards, electronic counters or PLC inputs.

Output circuit and recommended input circuit push-pull with inverted signals:

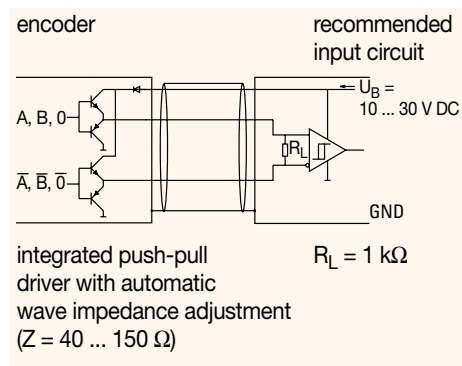

Output circuit and recommended input circuit push-pull without inverted signals:

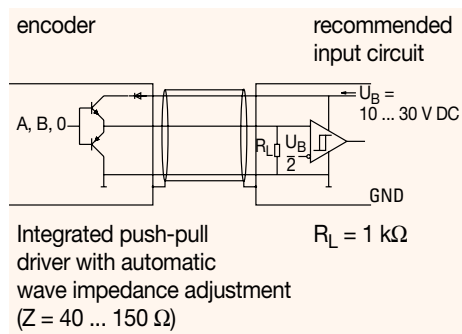

GENERAL/OVERVIEW

General

Sine wave outputs:

The sine wave signals are available as voltage signals. They can be further processed and can be multiplied by a factor of usually 10, 20, 50, 100, 400, 500, 1000 res. binary factors (512, 1024). Due to the interpolation of the two signals, which are 90° out of phase, a very high resolution can be achieved. This makes these kind of signals specially useful for applications where very high resolutions are required. Further they are very suitable for digital drives with a very slow and precise movement, e.g. for grinding machines or lifts and elevators.

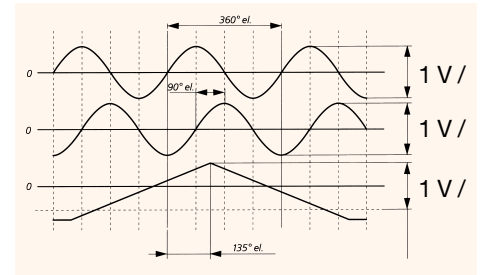

- Shaft turning clockwise, top view of shaft
- 0-pulse is generated once per turn

Output circuit and recommended input circuit for sine wave voltage signals:

$R_a = 10 \Omega$ $Z = 120 \Omega$
 $C_1 = 150 \text{ pF}$ $U_1 = U_0$
 $C_2 = 10 \text{ pF}$
 $R_1 = 10 \text{ k}\Omega$
 $R_2 = 33 \text{ k}\Omega$
 $U_0 = 2,5 \text{ V} \pm 0,5 \text{ V}$ OPV: z.B. MC33074

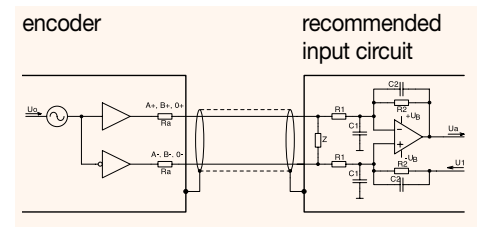

Cable length:

Depending on the output circuit and the electrical noise the following cable lengths are recommended:

Output circuit	max. cable length	Encoder connected to e.g.
Push-pull without inverted signals	100 m	counter/PLC
Push-pull with inverted signals	250 m	PLC/IPC ¹⁾
RS 422 with inverted signals	up to 1000 m (> 50 m depending on frequency)	PLC/IPC ¹⁾
Voltage sinus with inverted signals	50 m	PLC/IPC ¹⁾

1)IPC = industrial PC

Annotations:

- Depending on the application the recommended cable length can be shorter, especially in areas with strong electrical noise.
- Always use shielded cables
- The core diameter of the signal cores should be $\varnothing 0,14 \text{ mm}^2$
- The core diameter of the voltage supply cores should be large enough depending on the cable length, that the voltage supply of the encoder is high enough and the signals do not go below the minimum levels!

We strictly recommend the use of the cable types written down in the accessories.

GENERAL/OVERVIEW

General

Selecting an Absolute encoder

Design and function:

Absolute encoders have a disk with a digital coding on concentric tracks. This code is read by a Opto-Asic. A unique bit pattern is assigned to each position.

The advantage is, that after power failure true position verification is available as soon as power is up again, even if the shaft was moved during the dead state.

Advantage:

No reference drives after starting-up are necessary as with incremental systems. Safety is increased and the time taken for reference drives is saved.

Selecting an absolute encoder:

When selecting the right absolute encoder the following parameters should be considered in addition to the recommendations on page 8–10.

- Supply voltage
- Type of code
- Interface (SSI, parallel, fieldbus, 4 ... 20 mA)

Versions:

Singleturn encoders:

Depending on the number of divisions they generate up to 131072 (17 Bit) unique per turn. This corresponds to an angular resolution of 0,0028°. After one revolution the process re-starts.

Singleturn encoders can be used in applications where revolution is sufficient, e.g. measurement of angles, robotic.

Multiturn encoders:

They are available with up to 131072 (17 Bit) definite angular positions per revolution and in addition 4096 (12 Bit) definite revolutions. This corresponds to 70 billion definite positions.

Multiturn encoders can be used for positioning applications e.g. automatic storage, retired systems, lift elevators, cranes, machine tool, etc.

Code types:

Binary Code:

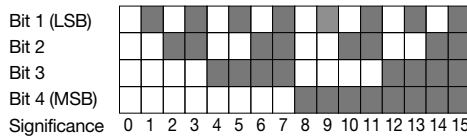

The binary code can be processed very easily by computer systems. When using optical read-out, errors may occur, because the change from one bit to another on the different concentric tracks (LSB, LSB+1...) is not exactly synchronized. Due to this, without any correction of the code, the position information could be wrong.

Gray Code:

The Gray Code is a single-step code. This indicates, that from one position to the next only 1 bit is changed. The reliability of the code detection is increased, which leads to a high position-reliability.

The gray code is used to optically read out the position for all absolute encoders

Symmetrically cut Gray Code (Gray-Excess):

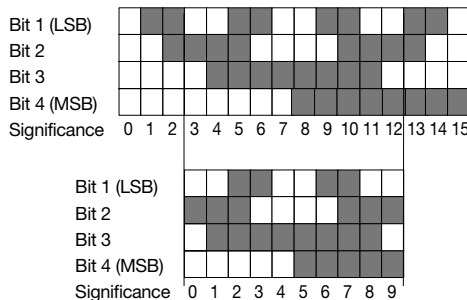

The extraction of a defined part of the gray code leads to the gray-excess code. This code enables the generation of non binary based divisions, e.g. 360, 720, 1000, 1440.

Reversion of the Gray Code:

The code values increase when the shaft is turning clockwise. If the most significant bit

(MSB) is inverted, the code values decrease when the shaft is turning clockwise



Optical disk in Gray code

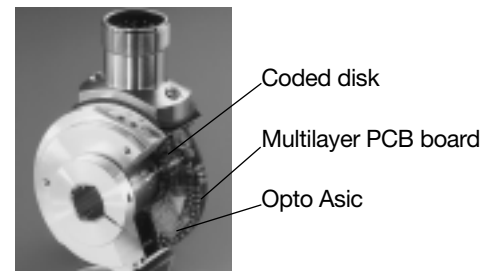

GENERAL/OVERVIEW

Interface

Outputs

To transfer the position data to a controller, different interfaces are available.

Parallel output:

This type of transfer is very fast. All bits of a position are transferred simultaneously each via a separate line.

Output circuit and recommended input circuit parallel interface:

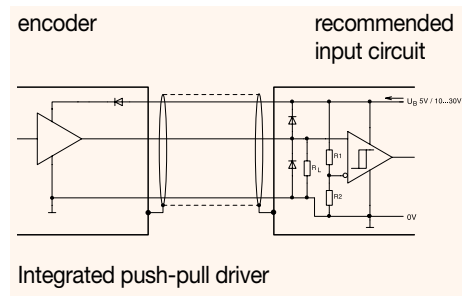

Synchronous Serial Interface (SSI): **SSI**

Compared to the parallel interface, the SSI interface needs less components and the EMC-characteristics are much better. In

addition less cores are needed for transmission and the possible cable length is much longer.

Output circuit and recommended input circuit of the SSI-Interface:

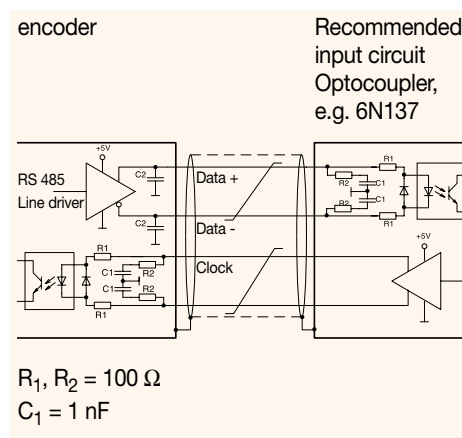

Synchronous-serial Transfer (SSI):

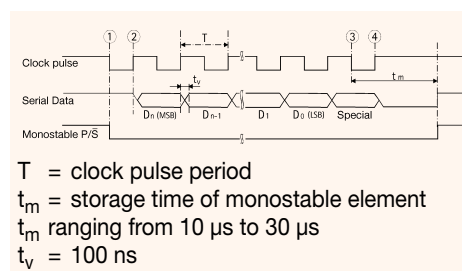

The number of clock pulses necessary for data transfer is independent of the resolution of the absolute shaft encoder.

The clock signal can be interrupted at any point, or continued in ring-register mode for repeated polling.

With the first shift of the clock signal from low to high ② the most significant bit (MSB) of the angular data is applied to the shaft encoder's serial output.

With each succeeding rising edge, the next less significant bit is shifted to the data output.

After transmission of the least significant bit (LSB) the Alarm bit or other special bits are transferred, depending on configuration.

Then the data line switches to low ③ until the time t_m has passed.

A further transfer of data cannot be started until the data line switches to high ④ again. If the clock pulse sequence is not interrupted at point ③, the ring-register mode is activated automatically. This means that the data stored at the first clock pulse transition ① are returned to the serial input si via the terminal so. As long as the clock pulse is not interrupted at ③, the data can be read out as often as wanted (multiple transfer).

GENERAL/OVERVIEW

Interface

Cable length:

Depending on the desired output circuit, we recommend following cable lengths:

Interface and output circuit	max. cable length	Connected to
Parallel CMOS/TTL	2 m	PLC/IPC ¹⁾
Parallel push-pull	100 m	PLC/IPC ¹⁾
SSI	up to 1200 m	PLC/IPC ¹⁾
RS 422 /RS 485	(> 50 m depending on frequency)	

¹⁾IPC = Industrial PC

Notes:

- Depending on the application the max. allowed cable length can be shorter, especially in areas with strong electrical noise.
- Always use shielded cables
- The core diameter of the signal cores should be $\varnothing 0,14 \text{ mm}^2$
- The core diameter of the voltage supply cores should be large enough depending on the cable length, that the voltage supply of the encoder is high enough and the signals do not go below the minimum levels!

We strictly recommend the use of the cable types written down in the accessories.

Connection – precautions

For the connection of the shield braids, refer to the logic control documentation. In all cases, for grounding, the braids must be covered through 360°. All unused conductors must be connected to the same potential at both ends.

Keep the encoder connection cables as far away from the power cables as possible and avoid running them in parallel. Finally, for the same regulated power supply, only connect encoders drawing the current that the power supply can deliver. Group the signals of the same type by pair, CLK+ with CLK-, DATA+ with DATA-.

SSI Transmission

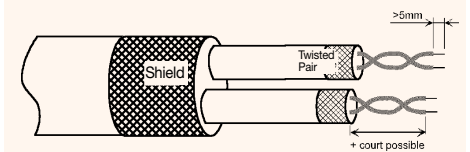

Type of connection and recommended input circuit

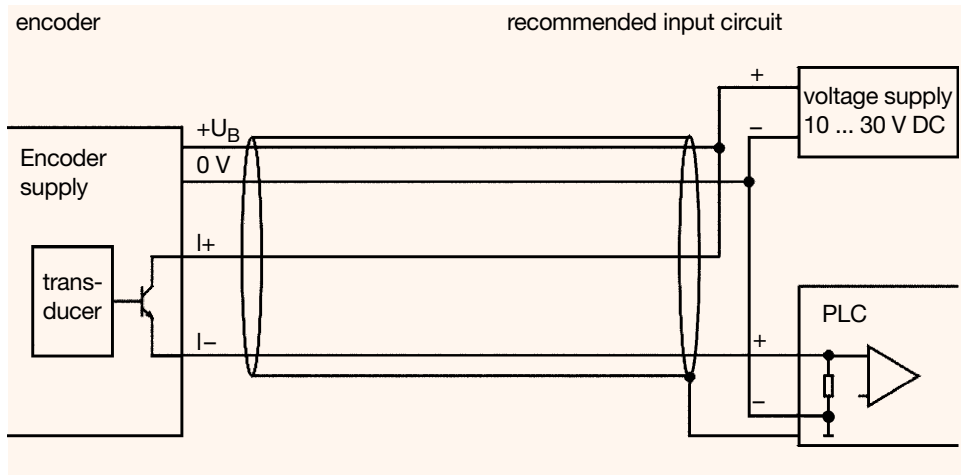

BiSS Sensor Communication Bi-directional and fully-digital

BiSS

BiSS is a fully-digital and bi-directional sensor interface. It defines communication between one master and several slaves (sensors) in industrial control systems. BiSS manifests a new standard in technology and is available license-free (GPL). Due to its high performance, it constitutes an efficient alternative to the standard combination of data interface and analog sine/cosine incremental output.

BiSS only needs a total of 6 lines (4 data, 2 power), does not require any hardware for analog signals (cable(s)/drive interpolation electronics) – and so helps to reduce system costs.

Bus Networking:

Up to 8 sensors can be connected to a bus-master. Wiring and control cost is considerably reduced for multi axle applications.



GENERAL/OVERVIEW

General

Bus systems:

The use of a network of sensor-actuator bus systems has essential advantages:

- Reduced expenditure concerning connection: All members are linked by one cable.
- Wide range diagnostics and programming possibility of the units.

In the following please find the available bus systems:



DeviceNet™



CANopen

CAN:

CANopen

- CAN fulfills the real time demands of the automobile industries (ABS, Airbag, Motormanagement)
- Multi-Master system
- The message text (speed, position...) itself is marked by an identifier through the whole network, instead of indexing the nodes.
- Check for importance of message
- Accept or ignore @ network wide broadcasting
- high allocation on the network
- Monitoring (high reliability)
- Bus Specification according to CAN High Speed ISO/DIN 11898 for transmission rates of up to 1 Mbaud.

Introduction

The Meyle CANopen encoder is an absolute encoder. The version described sends its current position to another station via the "CAN-bus" transmission medium (physically: screened and twisted two-wire line).

The serial bus system CAN (Controller Area Network), which had been originally developed for automotive uses, is gaining ground in industrial automation technology. The system is multimaster compatible, i.e. several CAN- stations are able to request the bus at the same time. The data transfer is regulated by the message's priority. The message with the highest priority (determined by the identifier) will be received immediately. Within the CAN system, there are message identifiers but no transport addresses. The message which is being sent can be received by all stations at the same time (broadcast). By means of a special filter method, the station only accepts the relevant

messages which is of importance for this station. The identifier transmitted with the message is the basis for the decision as to whether the message will be accepted or not.

The bus coupler is standardised according to the international standard ISO-DIS 11898 (CAN High Speed) and allows data to be transferred at a maximum rate of 1 MBit/s. The most significant feature of the CAN-protocol is its high level of transmission reliability (Hamming distance = 6). The CAN-Controller Intel 82527 used in the encoder is basic as well as full-CAN compatible and supports the CAN-specification 2.0 part B (standard protocol with 11-bit- identifier as well as extended protocol with 29-bit identifier).

Field of application

In applications, where the position of a drive or of other parts of a machine has to be recorded and signalled to the control system, the encoder can carry out this function. The encoder can resolve, for

instance, positioning tasks by sending the check-back signal concerning the present drive position via the CAN bus to the positioning unit.



Meyer Industrie-Electronic GmbH – MEYLE

Carl-Bosch-Straße 8 Tel.: (+49) 05481-9385-0 Internet: www.meyle.de
49525 Lengerich/Germany Fax: (+49) 05481-9385-12 E-Mail: sales@meyle.de

GENERAL/OVERVIEW

General

The CANopen Profile

CANopen allows for:

- synchronisation of the devices,
- auto-configuration of the network,
- comfortable access to all device parameters.

CANopen uses four communication objects (COB) with different features:

- Process Data Objects (PDO) for real-time data
- Service Data Objects (SDO) for the transfer of parameters and programs
- Network Management (NMT, Life-Guarding)
- predefined objects (for synchronisation, time stamp, emergency message)

- simultaneous data input and output.
- cyclical and event-controlled process data processing,

All device parameters are stored in an object directory. The object directory contains the description, data type and structure of the parameters as well as their addresses (index).

The directory consists of three parts:

- communication
- profile parameters,
- device profile parameters and manufacturer specific parameters.

Existing Profiles

The following device profiles already exist:

- CiA Draft Standard Proposal 401 for Input/Output Modules
- CiA Draft Standard Proposal 402 for Drives and Motion Control
- CiA Work Item 403 for Human-Machine Interfaces

- CiA Work Draft 404 for Closed-Loop Controllers and Transformers
- CiA Work Item 405 for IEC-1131 Interfaces
- CiA Draft Standard Proposal 406 for Encoders
- CiA Work Item 407 for Public Transport
- CiA Work Item 408 for Fork-Lifts

The encoder device profile (CIA DSP 406)

This profile describes a standardised and binding, but manufacturer-independent definition of the interface for encoders. The profile not only defines which CANopen functions are to be used, but also how they are to be used. This standard allows an open and manufacturer-independent bus system. The device profile consists of two object categories

- the standard category C1 describes all the basic functions the shaft encoder must contain

- the extended category C2 contains a variety of additional functions which either have to be supported by category C2 shaft encoders (mandatory) or which are optional. Category C2 devices thus contain all C1 and C2 mandatory functions as well as, depending on the manufacturer, further optional functions. In addition, an addressable area is defined in the profile, to which, depending on the manufacturer, different functions can be assigned.

DATA Transmission

In CANopen, the data is transferred by means of two different communication types (COB = Communication Object) with different features:

- Process Data Objects (PDO)
- Service Data Objects (SDO)

The priority of the message objects is determined by the COB identifier.

The process data objects (PDO) serve the highly dynamic exchange of real-time data (e.g. position of the shaft encoder) with a maximum length of 8 Byte.

This data is transferred with high priority (low COB identifier). PDOs are broadcast messages and put their information simultaneously at the disposal of all desired receivers. The service data objects (SDO) form the communication channel for the transfer of device parameters (e.g. programming of the shaft encoder's resolution). Since these parameters are transferred acyclically (e.g. only once when starting up the network), the SDO objects have a low priority (high COB identifier).



GENERAL/OVERVIEW

General

Profibus: General Information



The basic functions of the PROFIBUS DP are only described in extracts in here. For additional information, please refer to

the standards on PROFIBUS DP, i.e. DIN 19245-3 and EN 50170 respectively.

Introduction

The Meyle Profibus encoders are absolute encoders. The version described sends its current position to another station via the transmission medium "PROFIBUS DP" (physically: screened and twisted pair line). The Profibus encoder supports all class 1 and 2 functions listed in the encoder profile. PROFIBUS-DP is standardised and binding, but manufacturer-independent definition for a variety of applications in the field of production, process and automation. The requirements of openness and independence from the manufacturer are stipulated in the European standard EN 50 170.

PROFIBUS-DP permits the communication of devices produced by different manufacturers without any particular adaptations of the interfaces. PROFIBUS DP is a special standard version for a quick data exchange within the field level which has been optimised in terms of speed and low connection costs. Central with local field devices like drives, valves, or encoders. The data exchange between these devices is predominantly cyclical. The communication functions required for this exchange are determined by the functions of the PROFIBUS DP according to the EN 50 170 European standard.

Field of application

In systems, where the position of a drive or of any other part of a machine has to be recorded and transmitted to the control system, the encoder is doing this function. The encoder can resolve, for instance,

positioning tasks by sending the feedback signal concerning the present drive position via the PROFIBUS DP to the positioning unit.

Basic function of the Profibus DP

The central control system (master) cyclically reads out the input information from the slaves and transmits the output information to the slaves. For this purpose, the bus cycle time has to be shorter than the program cycle time of the central control system (e.g. SPC, or IPC), which amounts to approx. 10 ms for several applications. Beside the

cyclical user data transfer, the PROFIBUS DP version also disposes of powerful functions for diagnosis and initial operation procedures. The data traffic is controlled by watchdog functions on both the slave and the master side. In the following the basic functions of the PROFIBUS DP are summarised in short.

PROFIBUS DP Basic Functions

Transmission technology:

- RS-485 twisted pair line
- Baud rates ranging from 9.6 kbit/s up to 12 Mbit/s

Bus access:

- Monomaster or multimaster systems possible
- Token passing procedure between the masters and master-slave procedures for slaves
- Master and slave devices, max. of 126 stations at a single bus

Communication:

- Point-to-point (user data communication) or multicasts (control commands)
- Cyclical master-slave user data communication and acyclical master-master data transfer

Operating state:

- Operate: cyclical transfer of input and output data

- Stop: only master-master data transfer is possible
- Clear: The input data are read, the output data remain in the safe status
- **Synchronisation:** Control commands enable a synchronisation of the input and output data
- Sync mode: Output data are being synchronised

Functionality:

- Address assignment for the DP slaves via the bus
- Cyclical user data transfer between DP master and DP slave(s)
- Configuration of the DP master (DPM1) via the bus
- Single DP slaves are dynamically activated or deactivated
- Control of the DP slave's configuration.
- Powerful diagnostic functions, 3 stepped diagnostic message levels.

- Maximum of 246 byte input and output data per DP slave possible
- Synchronisation of in- and/ or output
- **Protection functions:**
- Access protection of the DP slaves' input/output
- All messages are transferred with a hamming distance of HD=4
- Response control at the DP slaves
- Monitoring of the user data communication with adjustable control timer at the master

Device types:

- DP master class 2 (DPM2), e.g. programming/ project planning devices
- DP master class 1 (DPM1), e.g. central automation devices like SPC, PC
- DP slave e.g. devices with binary or analogue input/output, drives, valves



Meyer Industrie-Electronic GmbH – MEYLE

Carl-Bosch-Straße 8 Tel.: (+49) 05481-9385-0 Internet: www.meyle.de
49525 Lengerich/Germany Fax: (+49) 05481-9385-12 E-Mail: sales@meyle.de

GENERAL/OVERVIEW

General

Diagnostic function

The extensive diagnostic functions of PROFIBUS DP allow a quick localisation of possible errors. The diagnostic messages

are transmitted by means of the bus and are joined together at the master.

System Performance

To ensure a high level of exchangeability between the devices, the system performance of PROFIBUS DP has also been standardised. It is mainly determined by the operational status of the DPM1. The DPM1 can either be controlled locally or via the bus by the project planning device. The following three main states are available:

Operate

The DPM1 has entered the data transfer phase. In case of a cyclical data traffic, the input is read by the DP slaves while the output is transferred to the DP slaves. After an error has occurred during the data transfer phase of the DPM1, like for example, the failure of a DP slave, the response of the system is determined by the operating parameter "Auto Clear". If this parameter has

been set to true, the DPM1 will set the output of all the respective DP slaves to the safe status, as soon as a DP slave is no longer available for user data communication. Afterwards, the DPM1 changes to the clear status. If this parameter is = false, the DPM1 remains, even if an error occurs, in the operate status, and the user can determine the response of the system at his own decision.

Stop

There is no data traffic between DPM1 and the DP slaves.

Clear

The DPM1 reads the input information of the DP slaves and maintains the safe status of the DP slaves' output.

Cyclical data transfer between DPM1 and the DP SLAVES

The data traffic between the DPM1 and the respective DP slaves is automatically handled by the DPM1 in a fixed, recurring order. When configuring the bus system, the user assigns a DP slave to the DPM1. In addition

the slaves are in- or excluded from the user data communication. The data traffic between the DPM1 and the DP slaves is subdivided in three phases: parameterisation, configuration, and data transfer.

Before including a DP slave in the data transfer phase, the DPM1 checks during the parameterisation and configuration phase,

whether the planned set configuration corresponds to the actual configuration of the device. For this check, the device type, the information on the format and the length as well as the number of input and output lines have to be correct. Due to this check it is ensured that the parameterisation is reliable and correct at the end. In addition to the user communication, which is automatically executed by the DPM1, the user can request the new parameterisation data to be sent to the DP slaves.