

GEARED CAM LIMIT SWITCHES

BRLS

- Combined worm/spur gears for high gear reductions requiring less mounting space; different, precisely graduated gear reduction
- Cam discs with precise adjustment
- Utilisation of switching contacts for switching voltages of 250 VAC, gold contacts on request
- Available with 4 contacts in 1 contact assembly block or 8 contacts in 2 contact assembly blocks
- Heavy duty ball bearing design
- Plastic housing IP 65
- 0,85 to 880 usable revolutions
- Potentiometer and up to 2 incremental or absolute encoder mounting possible



BRLS series geared cam limit switches are universal mechanical switching devices which present a large number of input shaft revolutions on the rotation angle of one single revolution of the cam discs.

The cam discs serve to operate the contacts.

BRLS series geared cam limit switches are used wherever specific ranges of travel can be limited indirectly only by switching devices.

Classical applications of these limit switches are lifting, travelling and slewing gears of cranes, yaw and pitch control in wind power stations, bucket elevators, etc. Especially where a danger to persons exists and the **use of positive opening switching contacts is required according to EN 60947, part 5 – 1, IEC 947 – 5 – 1**, the use of geared cam limit switches is the most efficient alternative.

Construction of the geared cam limit switch

The geared limit switch consists of a gearbox and switch combination which are located within a housing. The torque is positively transmitted from the input shaft to the switching shaft and, when using the precise adjustment "FV" of the cam discs, it is also transmitted up to the contact. The gear housing is made of glass – fiber reinforced synthetic material, the cap is not reinforced. Mounting as required.

Protection IP 65 to DIN VDE 0470 – 1 / EN 60529.

Working temperature -40 °C to +80 °C.

At 3 sides the housing is provided with pre – cut holes for cable entries which can be opened by the customer if necessary.

For fixing of the cable entries, insert fixing nuts. These nuts are protected against torsion. The thread lengths of the required glands are stated on the dimensional drawing.

The housing is provided with formed feet. If required, an additional flange can be screwed to the shaft input.



Special version with circuit board and encoder

Ordering Code/Key to Types

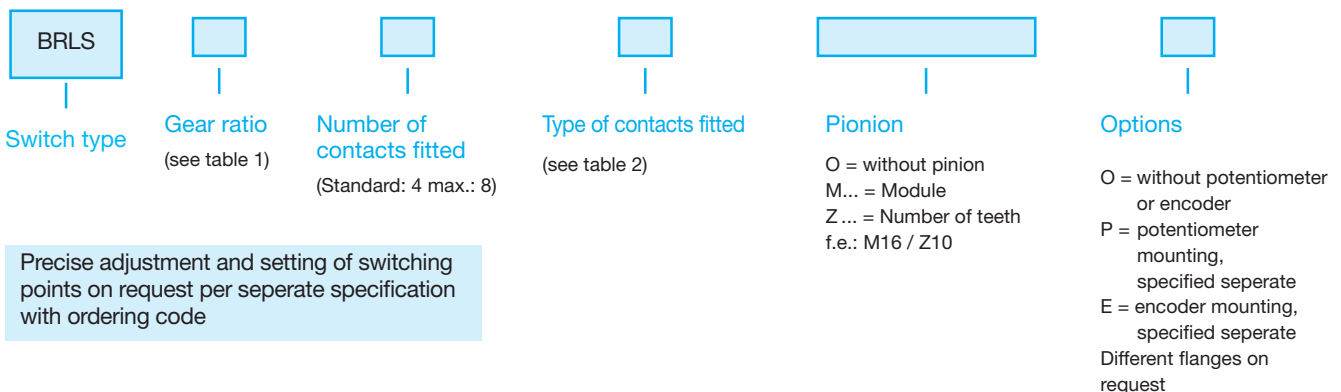

Precise adjustment and setting of switching points on request per separate specification with ordering code



Gear - Table 1 for contact S and SS with cam disc 40° ø 50							
Nominal revolutions	Usable revolutions (rounded)	Gear ratio i (rounded)	1 rev. of the drive shaft - corresp. to an ang. motion of cam disc = °	Reset rev. at driving shaft + / - 1%		Gear system	max. drive speed ¹⁾
				Clockwise rotation ²⁾	Counter-clockwise rotation ²⁾		
0.85	1	1	360	~0,03	~0,03	Straight bevel gear	200
1.85	2	2	170	~0,04	~0,04		
3.9	4	4	80	~0,05	~0,05		
6.0	6	7	53	~0,06	~0,06		
9.0	9	10	35	~0,07	~0,07		
15	15	17	21	~0,10	~0,10		
25	26	30	12	~0,15	~0,15	Worm spur gear	600
29	30	34	10.7	~0,40	~0,40		
53	53	60	6.00	~0,50	~0,50		
76	76	85	4.21	~0,60	~0,60		
95	95	107	3.35	~0,65	~0,65		
135	136	153	2.35	~0,80	~0,80		
180	186	209	1.72	~1,0	~1,0		
260	264	298	1.21	~1,3	~1,3		
360	362	407	0.89	~1,70	~1,75		
435	436	490	0.74	~2,00	~2,1		
515	515	580	0.62	~2,3	~2,4		
620	621	698	0.52	~2,7	~2,80		
880	884	995	0.36	~3,7	~3,9		

1) For short - time operation higher driving speed possible on request
 2) View of direction onto shaft

Table 2 / Contact Data

Contact designation	Contact type	Contact material	Switch actuation	Type of contact connection	Positive opening to EN 60947 -5 -1	Electrical data to EN 60947 -5 -1				Mech. life in mio. switching operations
						AC - 15 I[A]	U[V]	DC - 13 I[A]	U[V]	
S ¹⁾	Change - over contact	Silver	Snap action	Screw terminal	yes	1.5	230	0,5	60	10
SS ¹⁾				Flat plug 6,3						
SG ^{1) 2)}		Gold		Screw terminal						

1) Termal permanent current I_{th} = 10A; Reference insulation voltage U_i = 250V at pollution degree 3
 2) Contact SG for PLC applications (gold contacts)

Contact:
 S
 SS
 SG
 Change over switch



Contact connections
 The standard contact 99 has glands for 2 x 1.5 mm² cables.
 In the particular case the utilisation of switching contacts with flat plugs 6.3 x 0.8 mm is possible.
Caution!
 With connection voltages exceeding 25 VAC or 60 VDC, insulated flat plugs only must be used.



GEARED CAM LIMIT SWITCHES

BRLS

Cam discs

The cam discs are provided with 40 contact cams as standard. On request cam discs with any other cam angle can be provided at extra charge. Special cam discs are already made in our works as per the customer's specification.

For special cam discs with a firm program please provide a diagram similar to the below shown example drawing.



When not stating the cam angle on order placement, cam discs with a cam angle of 40 will be supplied.

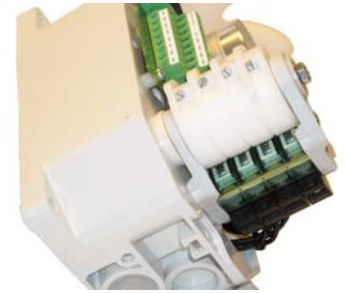

Cam adjustment by screws for each cam

The cam discs are designated according to their effective cam angle. With BRLS series cam discs, this corresponds to the switching point angle on the switching point radius of the cam disc. The production angle results from the design of the cam disc.

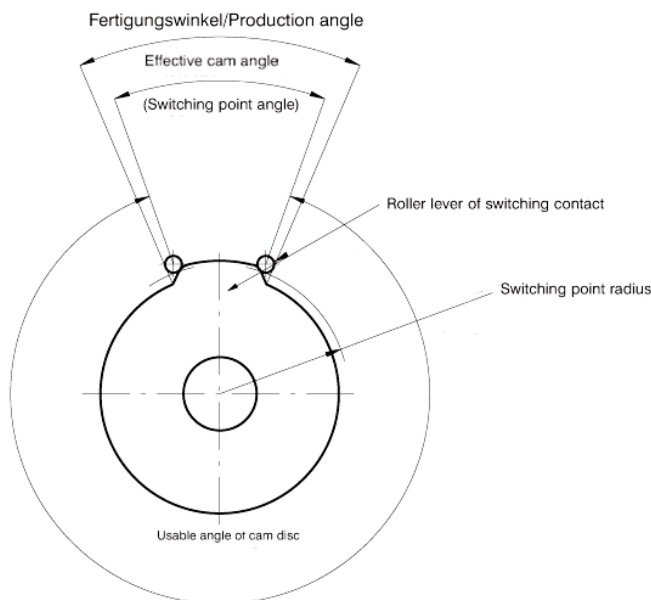

Example drawing

Contact	0	15	60	270	315	360
1	[Bar with shaded segment from 0 to 15]					
2	[Bar with shaded segment from 0 to 60]					
3	[Bar with shaded segment from 270 to 315]					
4	[Bar with shaded segment from 315 to 360]					

The usable number of revolutions of the drive shaft of a geared switch enable by a cam disc can be calculated as follows:

$$\frac{(360^\circ - \alpha \text{ (effective cam angle)}) \times I \text{ (gear reduction of switch)}}{360^\circ}$$

Construction

As a standard the BRLS series geared switches are always supplied in pedestal execution. Housing and feet form one piece; the feet cannot be removed.

As an option a flange can be screwed to the input side of the geared switch.

Generally the fixing bores are provided for the two flange executions. They can be used optionally. The assembly dimensions are stated on the dimensional drawing (fixing pitch circle 96 or 100 mm is possible).

Protection

The housing has protection IP 65 to DIN VDE 0470 – 1 / EN 60529. To improve the protection against water penetration, the cap is equipped with a protruding dropping edge, which also covers the sealing.



Meyer Industrie-Electronic GmbH – MEYLE
 Carl-Bosch-Straße 8 Tel.: +49 54 81-93 85-0 Internet: www.meyle.de
 49525 Lengerich/Germany Fax: +49 54 81-93 85-12 E-Mail: sales@meyle.de

GEARED CAM LIMIT SWITCHES



Dimensional figure pedestal execution

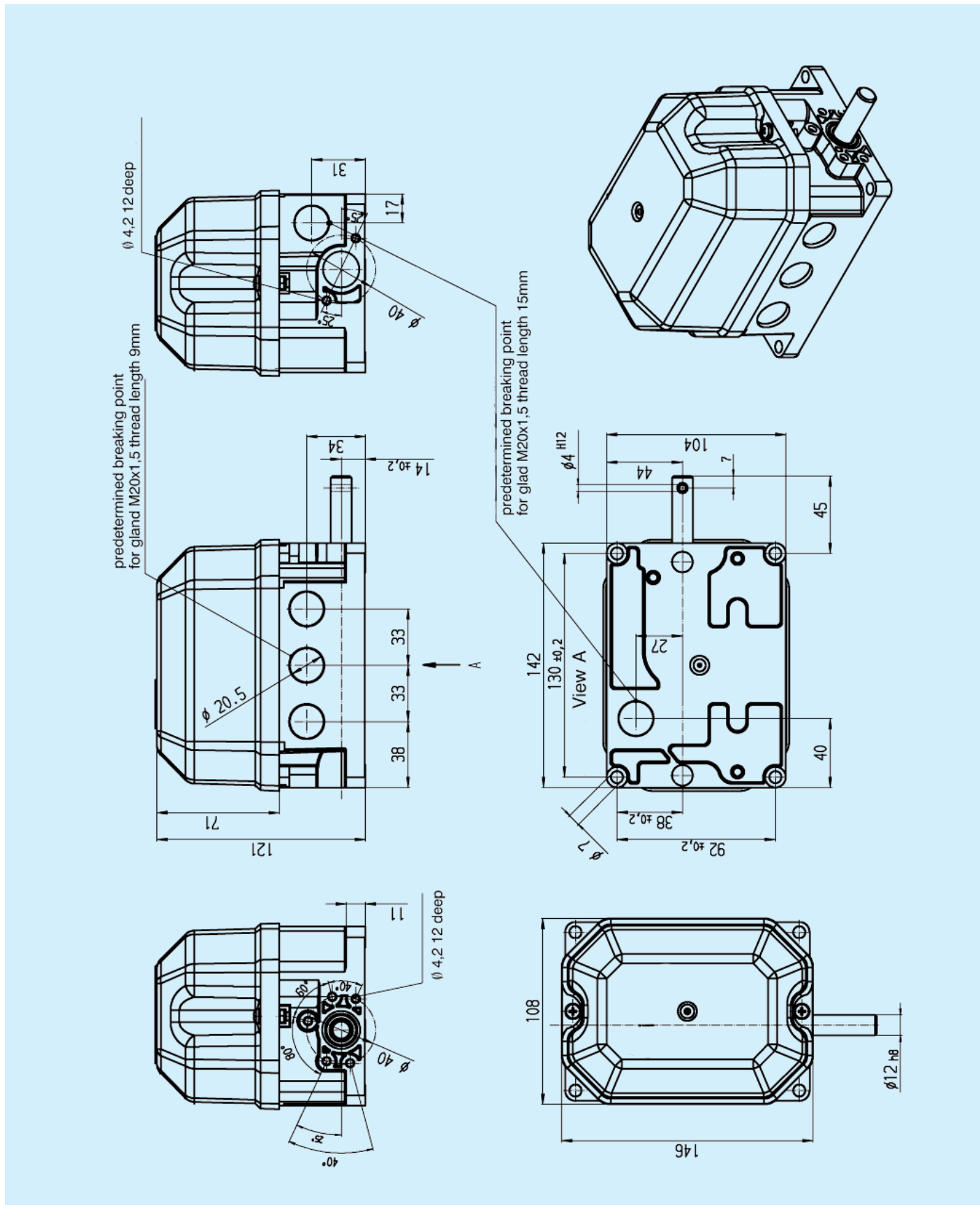

Meyer Industrie-Electronic GmbH - MEYLE
 Carl-Bosch-Straße 8 Tel.: +49 54 81-93 85-0 Internet: www.meyle.de
 49525 Lengerich/Germany Fax: +49 54 81-93 85-12 E-Mail: sales@meyle.de

GEARED CAM LIMIT SWITCHES

BRLS

1. Potentiometer mounting

Potentiometers having the same angle of rotation as the cam discs, are mounted instead of a cam disc assy. Potentiometers with central fixing or with servo - flange can be used. In the case that Stromag shall supply the potentiometers or in case of subsequent assembly, we ask to adhere to the below shown dimensions.

Cam discs and potentiometers can also be driven by various gear reductions. In case of such requirements please consult us.

2. Mounting of incremental encoders

As standard, the switch is provided with the possibility to mount an incremental encoder.

Instead of a contact block, the incremental encoder can be mounted. The input speed for the encoder complies with the speed of the input shaft of the geared switch. The encoder is connected through a printed circuit board with terminals. It is absolutely necessary to connect the encoder by screened cables.



Encoder data:

Please refer to MEYLE encoder catalogue 26 and 40 mm housing diameter incremental or absolute shaft encoders

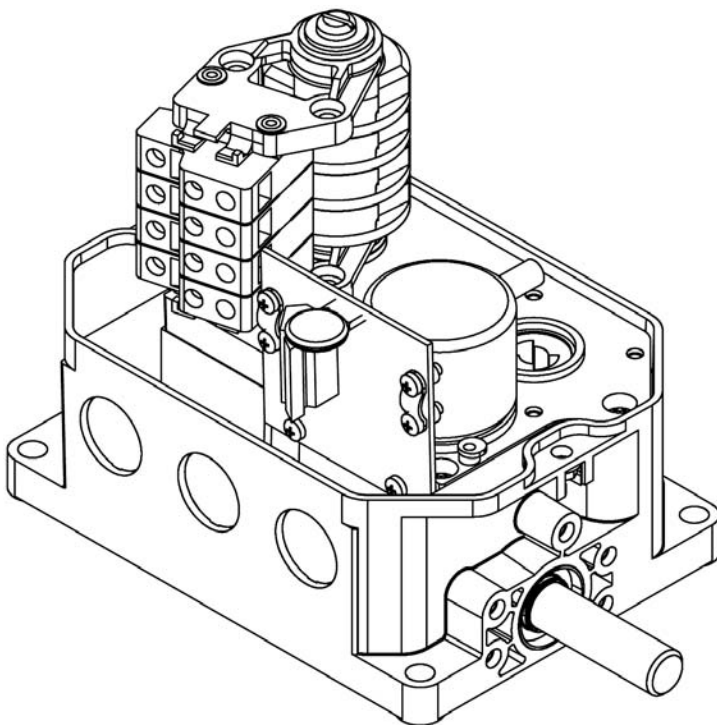

Special version with surge protection and encoder



Special version with one incrementale encoder and one absolute encoder

