

MAGNETIC SENSORS SMC-SMP SERIES AND MAGNETS



SMOOTH AND THREADED CYLINDRICAL MODELS
 PLASTIC AND METALLIC RECTANGULAR MODELS
 HIGH TEMPERATURE MODELS UPON REQUEST

TECHNICAL CHARACTERISTICS

Dimensions mm

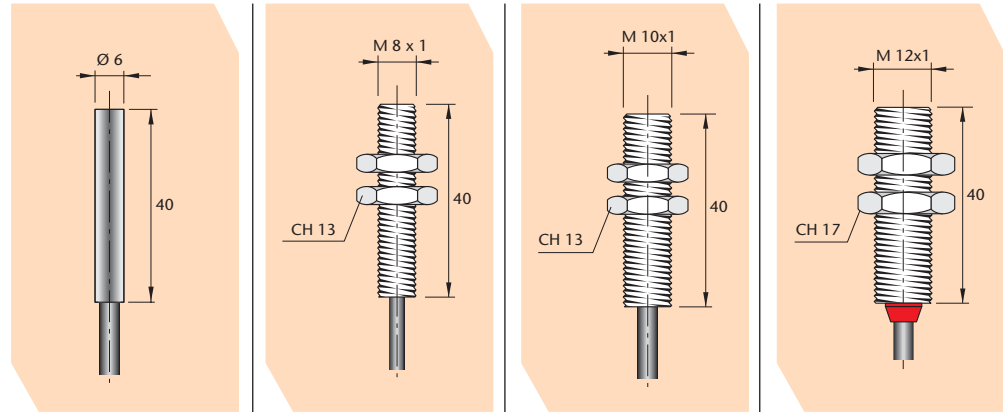

MODEL	NO	SMC06 NO		SMC08 NO		SMC10 NO		SMC12 NO	
CHANGEOVER MODEL	NO/NC		SMC06 S		SMC08 S		SMC10 S		SMC12 S
Max switching voltage	V	220	150	220	150	220	150	220	150
Max switching current	A	0.5	1	0.5	1	0.5	1	0.5	1
Max switching power	W/VA	10	20	10	20	10	20	10	20
Max switching frequency*	Hz	230	250	230	250	230	250	230	250
Contact actuation time	ms	2		2		2		2	
Repeatability	mm	± 0.3							
Temperature limits	°C	- 25 ÷ + 100							
Degree of protection	IP	67							
Housing		Nickelled brass							
Cable 2 metres length	∅ mm ²	2x0.14	3x0.14	2x0.25	3x0.14	2x0.25	3x0.25	2x0.25	3x0.25

* According to power and dimensions of the magnet together with distance between sensor and magnet.



WORKING PRINCIPLE

Magnetic proximity switches are made of reed contacts whose thin plates, trapped in a glass bulb together with inerted gas, are easily influenced by magnetic fields that create magnetic induction, opposite polarization. Magnetic attraction force makes thin plates flex and touch each other causing an electrical contact. The plate's surface has been treated with a special material particularly suitable for low current or high inductive circuits. Magnetic sensors compared to traditional mechanical switches have the following advantage:

- Contacts are well protected against dust, oxidization and corrosion thanks to the hermetic glass bulb and inerted gas; contacts are activated by means of a magnetic field rather than mechanical parts.
 - Special surface treatment of contacts assures in normal electrical conditions many of working cycles.
 - Maintenance free, reduce encumbrance.
- The reed magnetic switches offer many electrical and mechanical characteristics together with various output functions.
- When in normally open (N.O.) mode the open reed contact closes as magnet approaches. They are supplied with two wires.
 - When in the normally closed position (N.C.) the Reed contact, in rest position, opens as magnet gets closer. These models are created by using exchanging reed contacts in which N.O. output has been excluded. They are supplied with two wires.

- When in the exchangeable (S) mode both N.O. an N.C. functions are made available by means of a single glass bulb. Placing the magnet close to or far from the reed switch activates the two different positions. They are supplied with three wires, one is in common, one is N.O. and one is N.C.

TYPICAL REED CONTACT PROTECTIONS

The lifespan of a magnetic sensor, at low values of

tension and current, depends on the mechanical characteristics of the contact.

Whilst at high tension and current values it's the characteristics of the load that influences the lifespan instead. In these cases it is suggestable to apply some form of external protection at the sensors output.

TYPICAL REED CONTACT PROTECTIONS

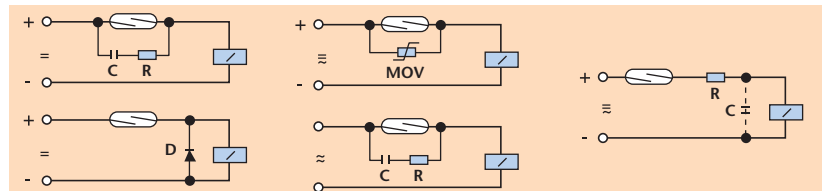

WORKING EXAMPLE

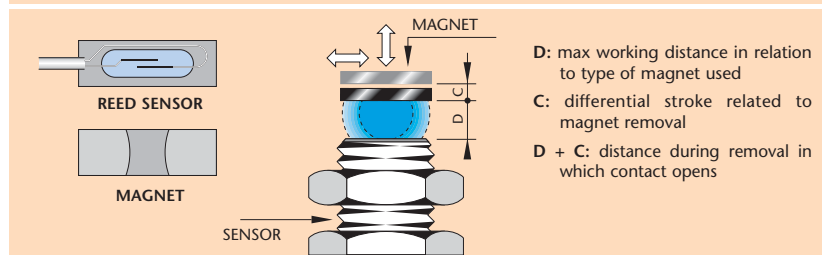

- D: max working distance in relation to type of magnet used
- C: differential stroke related to magnet removal
- D + C: distance during removal in which contact opens

Meyer Industrie-Electronic GmbH - MEYLE

Carl-Bosch-Straße 8
 49525 Lengerich/Germany
 Internet: www.meyle.de

Tel.: (+49) 05481/9385-0
 Fax: (+49) 05481/9385-12
 E-Mail: sales@meyle.de

MAGNETIC SENSORS SMC-SMP SERIES AND MAGNETS



SMOOTH AND THREADED CYLINDRICAL MODELS
 PLASTIC AND METALLIC RECTANGULAR MODELS
 HIGH TEMPERATURE MODELS UPON REQUEST

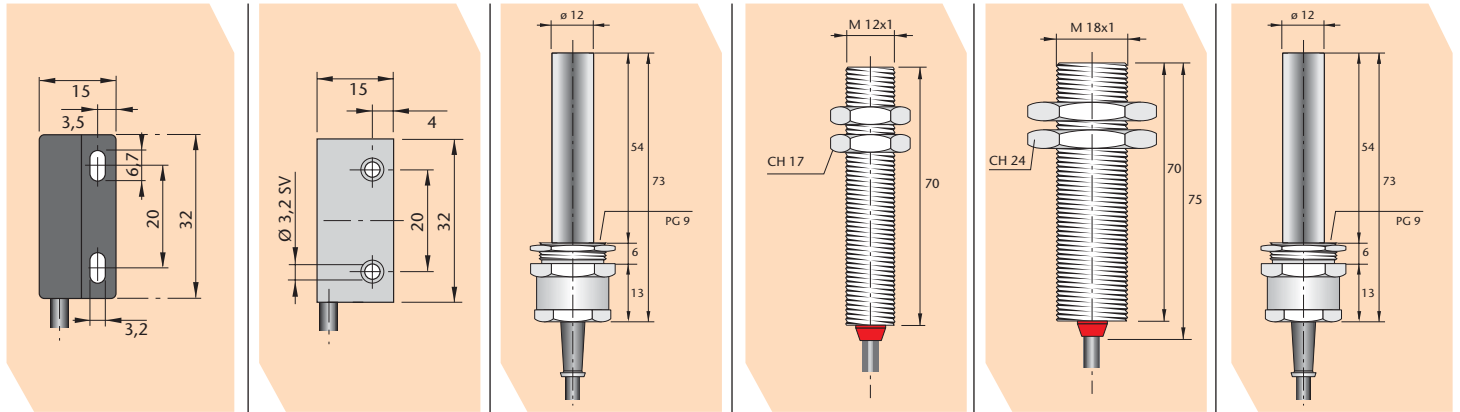

SMP302 NO		SMP304 NO		SMC09PG NO		SMC12LM NO		SMC18M NO		SMC09PGM NO	
SMP302 S		SMP304 S		SMC09PG S		SMC12LM S		SMC18M S		SMC09PGM S	
220	150	220	150	220	150	400	500	400	500	400	500
0.5	1	0.5	1	0.5	1	3	0.5	3	0.5	3	0.5
10	20	10	20	10	20	100	30	100	30	100	30
230	250	230	250	230	250		150		150		150
2		2		2		4.5		4.5		4.5	

± 0.3
 - 25 ÷ + 100
 67

Plastic				Nickelled brass							
2x0.25	3x0.14	2x0.25	3x0.14	2x0.50	3x0.35	2x0.50	3x0.25	2x0.50	3x0.35	2x0.50	3x0.35

SENSORS AND MAGNETS SENSING DISTANCE

SENSOR	REED	M16	M20	M30	M300	M302	M304
SMC-06/08/10/12/09PG	NO	8/2	20/4	40/5	30/4	-	-
SMC-06/08/10/12/09PG	CHANGEOVER	6/3	17/3	33/5	23/5	-	-
SMC-12LM/18M/09PGM	NO	-	10/6	33/10	18/8	-	-
SMC-12LM/18M/09PGM	CHANGEOVER	-	10/6	30/10	18/8	-	-
SMP-302/304	NO	-	-	-	-	10/4	10/4
SMP-302/304	CHANGEOVER	-	-	-	-	10/4	10/4

The above table states 2 distance values (D/C) in mm. D indicates the sensing distance, C indicates the min. hysteresis value, under this value the contact switches off (see example of functionig). Data shown on the above table have an approximate value, referred to appliances which are not ferromagnetic and with magnet for frontal working. The magnetic sensors can also work with a lateral magnet. In case of setting-up on ferrous surfaces which scatter the magnetic flux, it is necessary to interpose suitable spacers made of non-magnetic metal.

MAGNET - DIMENSIONS mm

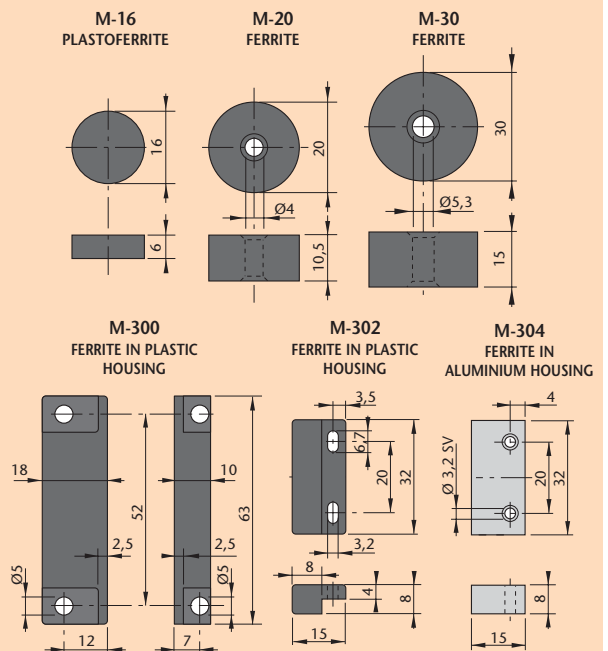

N.B.: Upon request magnets of different sizes. Type M-300 is supplyable without plastic housing, M-300F only in dimensions 39 x 15 x 8 mm.

WIRING DIAGRAMS

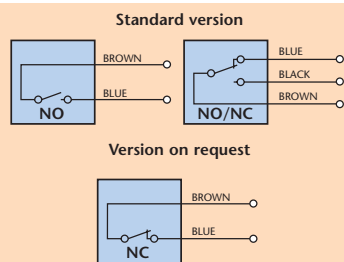

N.B.: On request is available cable for sensors with different length 3.5 - 7.5 - 5 - 10 metres.

SWITCHING POWER DIAGRAMS

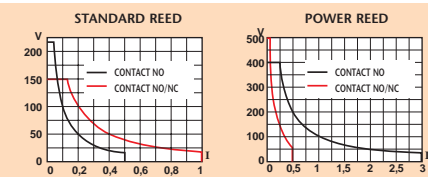

Voltage (V), switching current (I) and max. power (P) mean the max. switching instantaneous value in presence of loads. When choosing a type of contact it is recommended that the following formula be applied: $P = V \times I$.

For magnetic sensors which have different technical data from shown standard ones and for the switching of inductive or capacitive loads our technical department is always at your disposal.

Meyer Industrie-Electronic GmbH - MEYLE

Carl-Bosch-Straße 8
 49525 Lengerich/Germany
 Internet: www.meyle.de

Tel.: (+49) 05481/9385-0
 Fax: (+49) 05481/9385-12
 E-Mail: sales@meyle.de