

Pull Rope Emergency Switch

Type NSR

VDE approved

Technical Data



Application

According to DIN / VDE 0660 T200 / T210, EN 418, and the general stipulations of the incident prevention order VB610, devices or entire industrial machines and installations must be able to be switched off as quickly as possible by activating an emergency switch-off device in the case of possible danger to persons or damages to machines and installations.

The pull rope emergency switches types NSR (with fork lever) are meeting the standards of DIN / VDE 0660 T200 / T210 and EN418. These switches must be used in control current circuits only. They serve as devices to prevent incidents, injuries and damages to production assets as e.g. conveyor belts in the iron & steel industry, mineral exploitation industry, loading & unloading facilities, chemical industry and mining.

The pull rope emergency switch type NSR including accessories is for installation on the accessible side of conveyor belts or machines. It can be activated at any point of the line surveyed (an advantage over push-button type emergency switch-off is distributed in distances over the line to be monitored) and, depending on the switching logic, deactivate one or more drives or an entire complex, too.

Configuration and Features

The rope switch consists of a weather proof glass fibre reinforced plastic housing (yellow RAL 1004) with enclosure IP65. It is equipped with two holes for leads PG 16 which are plugged for shipping (do not use in operation). The switching mechanism makes the pull rope emergency switch staying operational even in case of broken springs.

Its fail safe features correspond to the EN418 and the recommendations of the trade association: The pull rope emergency switch locks automatically and self driven after activation and can be reset only by the reset lever at the switch. If required, the reset lever can be made lockable as well. The item is available with 1, 2, or 3 switching elements cogently operated by the switching mechanism. Additionally, a signal lamp can be accommodated in the cover.

With the pull rope mounted on both sides of the activation lever a line length of about 100 m (max. 150 m) can be monitored. The switch will be activated automatically by pre-loading via pull springs in case of a rope rupture on one side.

Mode of Operation

The pull rope emergency switch type NSR 01/02/03 is operated by a 50 m (max. 75 m) pull rope (steel rope, red plastic coated, dia. 5 mm) on each of the two sides. The triggering of the mechanism will be caused by pulling the pull rope.

At an angular deviation from the mid position of about $10^\circ \pm 3^\circ$ (activation force = $50 \text{ N} \pm 15 \text{ N}$) the patented switching mechanism is activated.

This mechanism in turn suddenly activates the control switches and cogently guides the switch lock into end stop position. The activated (pushed-down) position of the control switches can be unlocked only by the reset lever.

The control switches feature a cogent separation characteristic and correspond to the international safety standard EN418. The NC contact (normally closed) opens the safety chain of the control and effects a switch-off of the subsequent device.

Pull Rope Arrangement, Version A

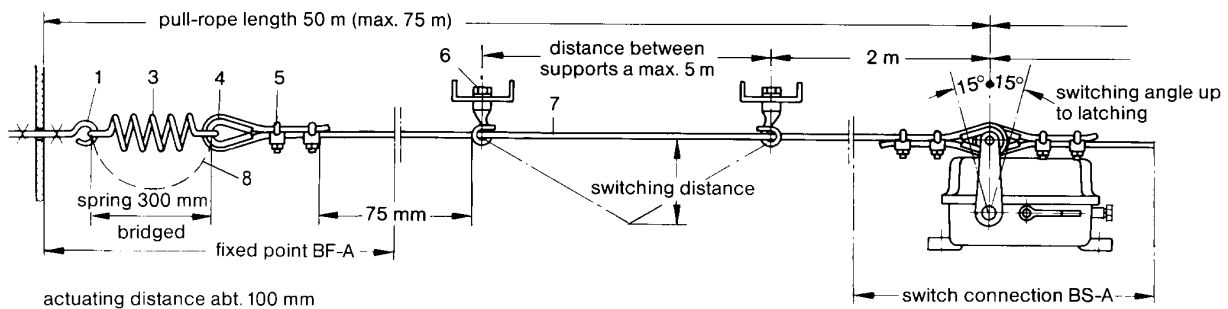

Pull Rope Arrangement, Version B

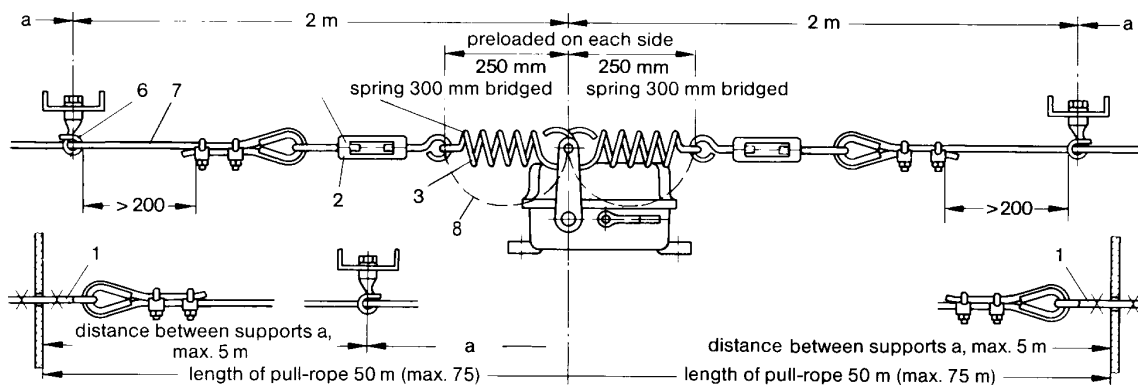

Accessoires:

1 eye screw M6x60	4 rope eye 3/16"	7 pull rope: steel rope with red PVC sheathing
2 turnbuckle M6x110	5 rope clamp 3/16"	diameter 5mm
3 spring RZ 168	6 wire loop M 8 x 80	weight 0,039 kg/m
	with bolt	tensile strength 1600 N/mm ²
	8 spring bridge	rope elongation 0,012 mm/m °C

To ensure a safe switch-off when the rope is ruptured, both springs (3) must be pre-loaded to an extent, that the distance between the eyes amounts at least to 250 mm and the activation lever is in mid position:

- a) Rough adjustment at the rope end, b) refinement at the turnbuckle.

distance between supports a [m]	2	2,5	3	3,5	4	5
switching distance s [mm] ca.	280	310	340	360	390	430

Technical Data

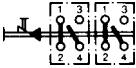
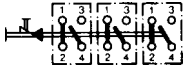
Type	NSR 01	NSR 02	NSR 03
Circuit connection			
Switching units	1 x S 826 e	2 x S 826 e	3 x S 826 e
Switching performance		400 V ~ cos j = 1/0,4 230 V ~ cos j = 1/0,4 80 V - t = 0/5 ms 60 V - t = 0/5 ms 24 V - t = 0/5 ms 10 A	3 A / 2 A 0,5 x 10 ⁶ switchings 3,7 A / 7 A 0,5 x 10 ⁶ switchings 8 A / 3 A 10 A / 4 A 16 A / 9 A
Duration current I _{th2}		1A / 230 V	
Switching capability for VDE-classification AC 15		0,5 A / 110 V	
Switching capability for VDE-classification DC 13		hard silver	
Switching contact material		(gold plated switching contacts available for low voltage operation)	
Switching contact gap		1,6 mm	
Switching contact durability		5 x 10 ⁵ switchings	
Activation velocity		> 0,5 m/s	
Dimensioned nominal insulation voltage		380 V AC	
Insulation class		VDE 0110 C	
Connecting Ports		0,75 to max. 2,5 mm ²	
Short cut protection required (fuse)		10 A	
Specifications met		DIN VDE 0660, Part 200 and 210, i.e. IEC 947-5-1 VDE 0110 UVV - VBG 10 EN 418, IEC 529	
Application		Devices and controls to VDE 0100 and 0113	
Housing		GFK (Glass fibre reinforced plastic), resistant against water solutions of salts, acids, and alkalines, alcohol and solvents.	
Colour		Housing: yellow, RAL 1004 Operation and reset lever: red, RAL 3000	
Weight		1kg approx.	
Enclosure (according to DIN 40050)		IP 65	
Installation orientation		Preferably upright, i.e. activation lever up	
Mechanical durability		1 x 10 ⁵ switchings	
Attachment to the operation lever		Bolt, ø 8mm stainless	
Cable routing		Threaded holes, 2 x PG16	
Ground connection		in housing	
Permissible environment temperature		Storage -40°C...+85°C Operation -40°C...+85°C Transport -40°C...+85°C	
Switching angle		10° ± 3°	
Activation angle		15° +3°	
Activation force		55 N ±15 N	
Switching principle		Snap switch with activation cam, cogently separated	
max. equipment		3 circuit openers and 3 circuit closers (with signal lamp max. 3 circuit openers and 3 circuit closers)	
Signal lamp (Option)		24, 42-220 V B15D max. 5 W	
Special accessory		Gold plated switching contacts (low voltage operation)	
Exchange with predecessor NSR 11/12/13		By adapter plate the NSR 11/12/13 can be mounted on the attachment flanges with the holes arrangement of the predecessor NSR 11/12/13	

Safety Instructions

- The plugs are only for dirt protection, they are not for use in operation
- PG-screwings must be sealed with an o-ring against the housing
- PG-screwings which are not in use must be closed by a plug and sealing
- The inner cabling must be routed in a way that a single wire cannot fall into the mechanical arrangement in case of a becoming loose. This is preferably achieved by cable binders holding together all single wire.

The following must be inspected periodically during operation of a pull rope type emergency switch-off device:

- Safe attachment of the emergency switch-off device
- Tightness of the switch cover
- Cleanliness of device (wire, rope, marking) for easy recognition
- Damage freedom of wire or rope from wear, corrosion, or impact
- Sufficient tightness of wire or rope
- Absence of signs for damage (cracks, corrosion, deformation) at switch
- Damage freedom and tightness of rope attachment devices
- Proper and safe attachment of pre-loading springs
- Damage freedom and cleanliness of guidance loops

- Cleanliness and release of rope supporting wheels
- Absence of foreign particles in influences collected at the device which could obstruct activation parts
- Absence of obstacles near the wire or rope

Periodical Check for proper Function

The proper function of the emergency switch-off device is checked during stopping the machine by the device or by observing the device during standstill of the machine:

- Easy movability of wire or rope through the guidance loops
- Easy movability of the activation parts and all parts transmitting the movement to the switch
- Safe locking of the activation lever in the off-position
- Activation lever must not release easily
- Sufficient strength and tightness of pre-loading springs for reliable emergency switch off in case of wire or rope rupture

In case of anomalies detected during inspection, these are immediately to be solved or the item concerned is to be replaced for further investigation.

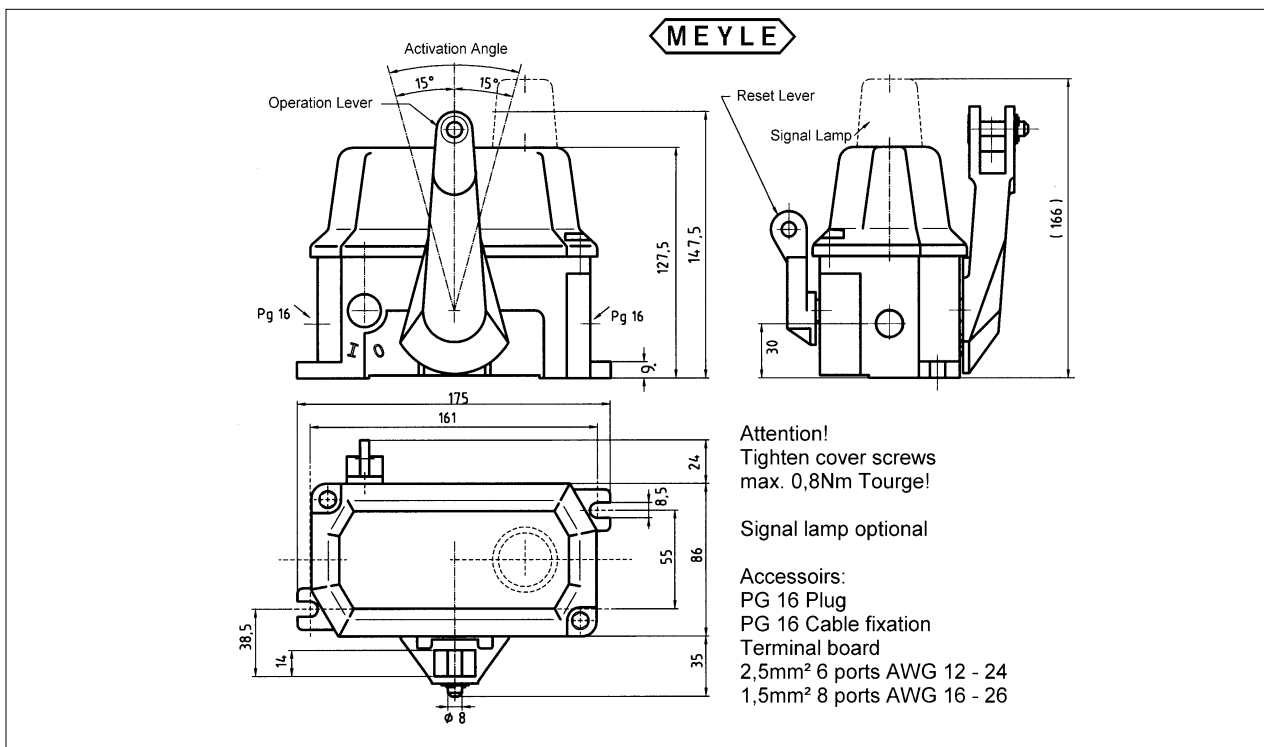

Dimensions NSR

06.414/0298 (Subject to alteration)

Meyer Industrie-Electronic GmbH
Carl-Bosch-Str. 8, D - 49525 Lengerich

Telefon +49-5481-9385-0 Telefax +49-5481-9385-12
Internet <http://www.meyle.de> E-mail sales@meyle.de