

Off-Track Belt Switches Type BSR and Type BSO VDE-approved



Application

The straight run of troughed conveyor belts is a decisive factor in safe, economic operation. In spite of several mechanical precautions, external influences caused by local conditions may effect the belt's straight running.

The most frequent causes for slant running are

- soiling of the support rollers and tail belt drums
- off-center material loading

If such or similar situations occur, the conveyor belt concerned and the supply belts are to be switched off to prevent damage, destruction, spillage of material, erroneous discharge, and the resulting expensive consequences.

ASG supplies practically proven off-track belt switches as safety devices for supervision of the belt run.

Configuration and features

Operating mechanism and switching elements of the switches type BSO and BSR are accommodated

in a sturdy, glass-fiber reinforced plastic housing, enclosure IP 65, which meets heavy duty requirements in any respect.

It is equipped with two holes for leads PG16 which are plugged for shipping (plugs not for use in operation). The switching mechanism makes the off-track belt switch staying operational even in case of broken springs.

The off-track belt switch type BSO is provided with a switch mechanism **without** latch, the type BSR **with** an effective latch when being operated. The release cam lever snaps into the latches only when the switching position is reached. It can be released only locally with a tight mounted release lever.

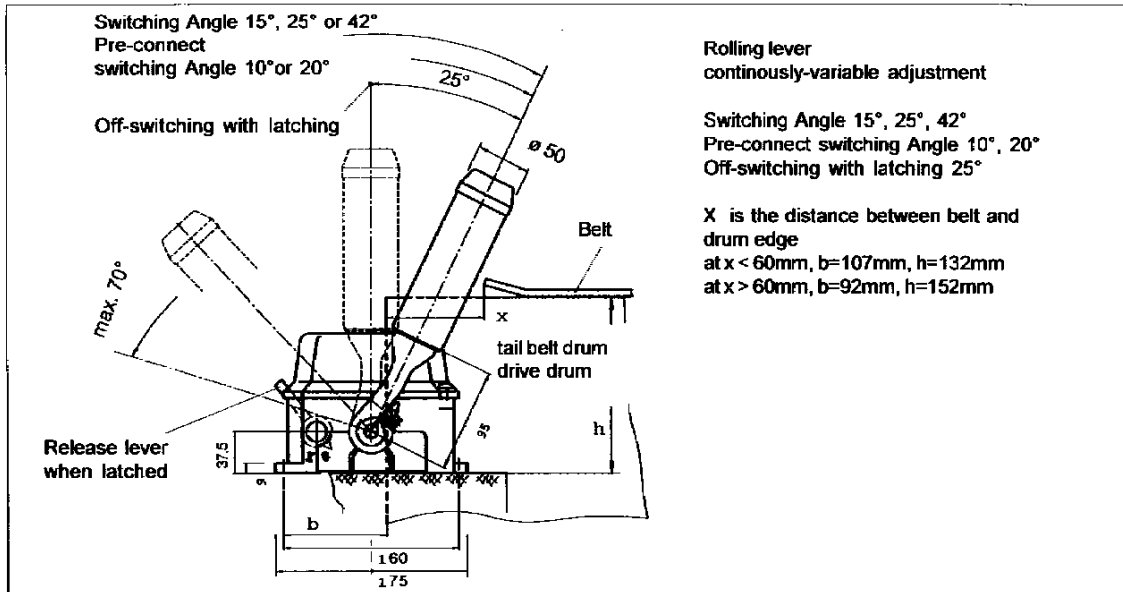

Arrangement of the off-track belt switch on the conveyor system

The off-track belt switch type BSO 0.. is available with max. three switching elements, while at the type BSR 0.. the status of the latching is indicated by an additional switching element.

At the types BSO.. +V and BSR.. +V max. two switches are dedicated to connecting at a rolling lever deflection of 15°, 25°, and 42° and one switch is dedicated to a pre-connecting at a lever deflection of 10° or 20°. The switching angles are selected by removal of the corresponding cams on the cam discs at all types of BSO and BSR.

The max. rolling lever movability (deflection) amounts to 70° to both sides.

The items in fact do not require any maintenance by the patented switching mechanism. If required, the items are available with a signal lamp integrated into the cover.

Mode of Operation

Off-track belt switches of types BSO 0.. and BSR 0.. are mounted on both sides of the conveyor belt close to the drive drum and the tail belt drum. Very long conveyor belts require further off-track belt switches.

The type BSR prohibits an unintended, automatic re-starting because it must locally be released.

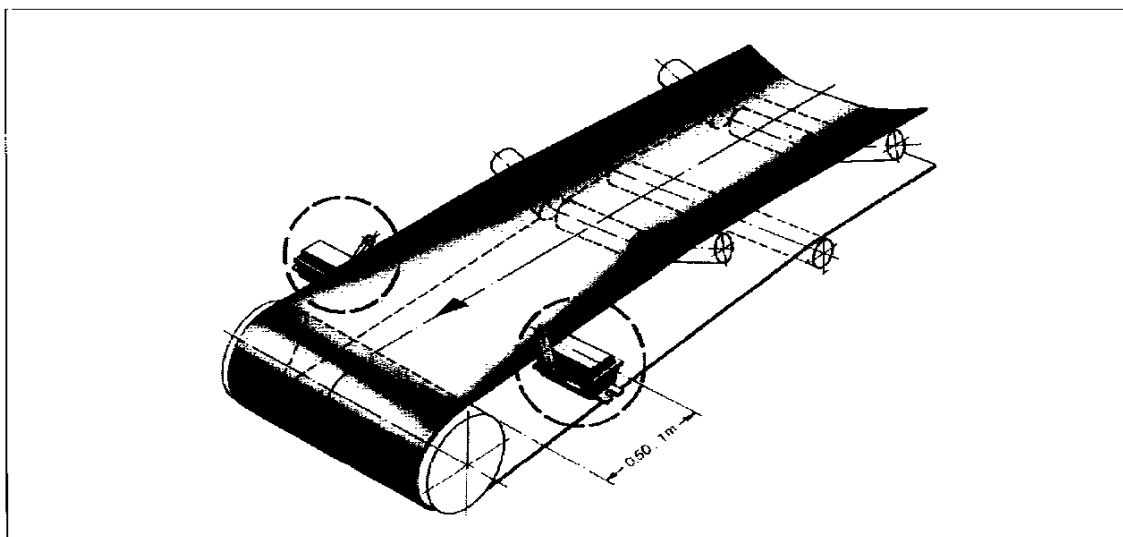

Both types ensure a high switching safety. The switching elements used have pre-loaded spring contacts and cogent-opening system and, by this, meet international standards.

The switching elements are appropriate to solve switching problems and to control optical or acoustical reporting devices as well.

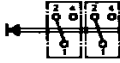

Mounting example BSR / BSO

Technical Data

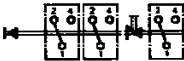
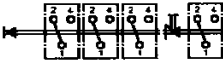
Type BSO	BSO 01	BSO 02 BSO 01 +V	BSO 03 BSO 02 +V
Connection			
Switching elements	1 x S 840	2 x S 840	3 x S 840
Type BSR	BSR 01	BSR 02 BSR 01 +V	BSR 03 BSR 02 +V
Connection			
Switching elements	2 x S 840	3 x S 840	4 x S 840
Duration current	230V/6A (at Ohm charge)		
Isolation	2,5 KV/3 (VDE 0110)		
Switching contact durability	3 x 10 ⁵ switchings; switching frequency 150/h		
Switching contact gap	0,75 to max. 1,5mm ²		
Short cut protection required (fuse)	6 A		
VDE-Classification	AC 11		
Specifications met	EN 60 947-5-1 (DIN VDE 0660 T200) EN 60 947-5-1 / A1 (DIN VDE 0660 T200 / A1)		
Application	Devices and controls to VDE 0100 and 0113		
Housing	GFK (Glass fibre reinforced plastic), resistant against water solutions of salts, acids, and alkalines, alcohol and solvent		
Colour	Housing: yellow, RAL 1004 Reset lever: red, RAL 3000		
Weight	1,8 kg approx		
Enclosure (according to DIN 40050)	IP 65		
Installation orientation	Preferably upright, i.e. activation lever up		
Mechanical duration	1 x 10 ⁵ Switchings (according to DIN 46 247 part 2, version 4, point 3, section 4.21 and DIN 41 636 part 1, point 6.9)		
Cable routing	threaded holes, 2 x PG16		
Ground connection	in housing		
Permissible environment temperature	Storage	-40°C...+85°C	
	Operation	-40°C...+85°C	
	Transport	-40°C...+85°C	
Max. equipment	3 alternating switches (BSO) 4 alternating switches (BSR)		
Signal lamp (Option)	12, 24, 60, 220V max. 5 W		
Exchange with predecessor	By adapter plate the BSR 0... / BSO 0... can be mounted on the attachment flange with the holes arrangement of the predecessor BSR... / BSO...		

Safety Instructions

- The plugs are only for dirt protection, they are not for use in operation
- PG-screwings must be sealed with an sealing against the housing
- PG-screwings witch are not in use must be closed by a plug and sealing
- The inner cabling must be routed in a way that a single wire cannot fall into the mechanical arrangement in case of a becoming loose. This is preferably achieved by cable binders holding together all single wire

The following must be inspected periodically during operation of an off-track belt switch:

- Safe attachment of the off-track belt switch
- Cleanliness of item and freedom from belt loading material and similar particles
- Absence of signs of damages like cracks, corrosion, deformation
- Absence of foreign particles in influences

collected at the device which could obstruct activation parts

- Absence of obstacles near the roller lever

Periodical Check for proper Function

The proper function of the off-track belt switch is checked during stopping the conveyor belt by the device or by observing the device during standstill of the conveyor belt:

- Easy movement of rolling lever and movement from transmitting parts
- Reliable selflatching of rolling lever in Off-Position
- Release of rolling lever not too easy

In case of anomalies detected during inspection, these are immediately to be solved or the item concerned is to be replaced for further investigation.

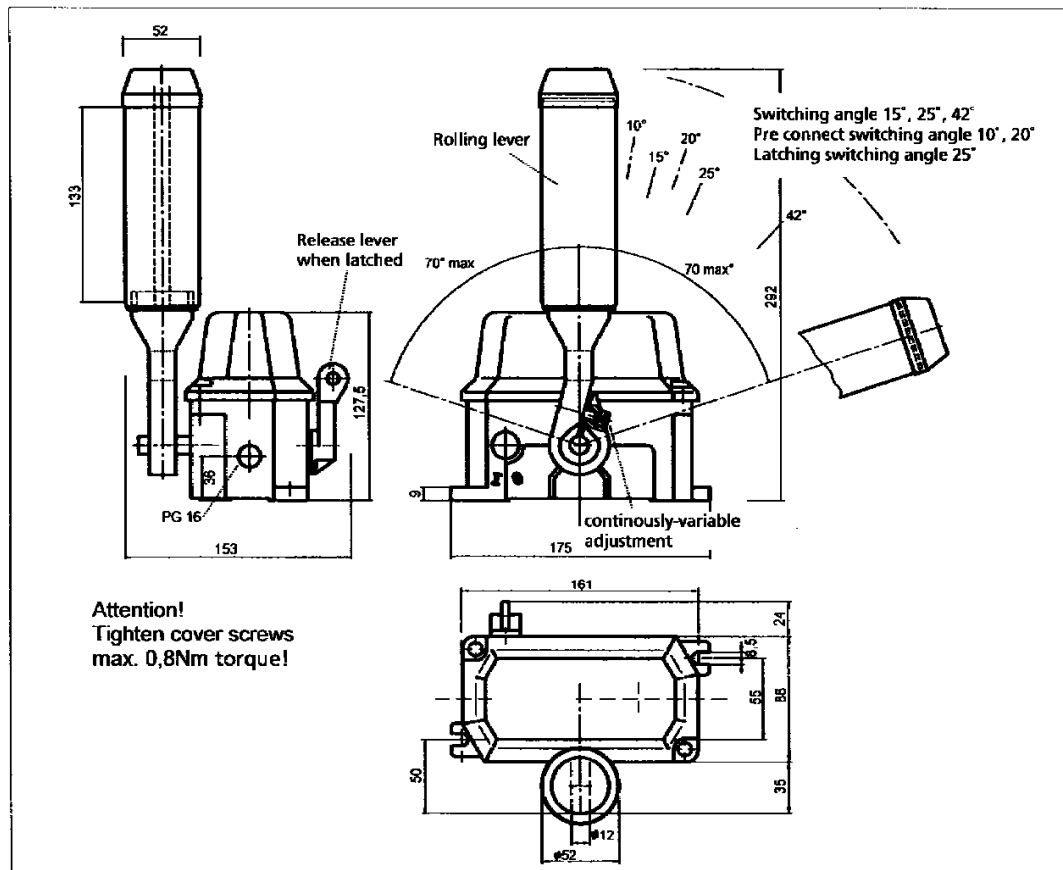

Dimension BSO / BSR

06.417/0498 (Subject to alteration)



Meyer Industrie-Electronic GmbH
Carl-Bosch-Str. 8, D - 49525 Lengerich

Telefon +49-5481-9385-0 Telefax +49-5481-9385-12
Internet <http://www.meyle.de> E-mail sales@meyle.de